



User manual

Battery energy storage system

HHS-1X5K

HHS-1X10K

HHS-1X15K

HHS-1X20K

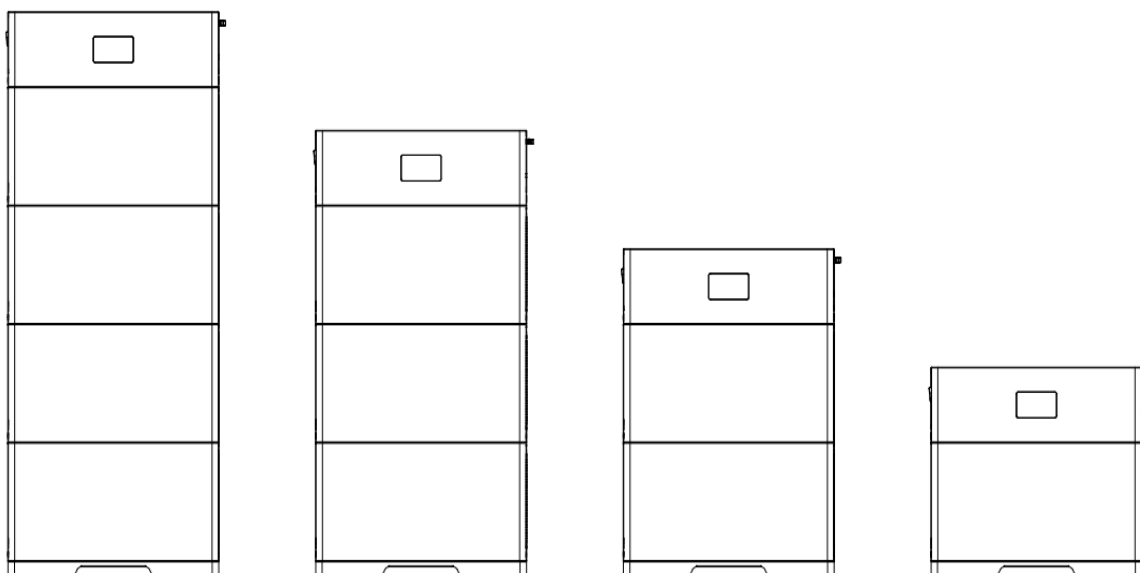

Version: V1.2

Content

1 Safety precaution	1
1.1 Storage and installation environment	1
1.2 Battery safety guidelines	1
1.3 Warning signs and stickers	1
1.4 Emergency handling	2
1.5 System lock function	2
2 Product description	3
2.1 Product introduction	3
2.2 Appearance description	5
3 Installation guide	7
3.1 Environmental requirements	7
3.2 Installation physical requirements	8
3.3 Installation	9
3.3.1 Installation tools	9
3.3.2 Packaging components	10
3.4 Installation steps	11
4 Electrical connections	22
4.1 Grounding instructions	22
4.2 Power connector installation	22
4.3 Cable connection	25
4.3.1 External DC Circuit breaker for HHS Installation	25
4.3.2 Wiring Connections for HHS	25
4.3.3 Communication Interface Definition of HHS Battery system	27
4.3.4 Parallel HHS Battery System	27
5 Power up battery system	32
5.1 System power up	32
5.2 System power off	32
5.3 Display description	32
5.4 System configuration	33
6 Maintenance and troubleshooting	36
6.1 Routine maintenance	36
6.2 Fault checklist	37
6.3 Addition of new battery module or replacement guidelines	40
7 Warehouse storage guidelines	41
7.1 Packaging guidelines	41
7.2 Storage	42
8 Dispose of used batteries	43
9 Detailed specifications	44

1 Safety precaution

Read the manual carefully and operate in accordance with the safety precautions. Refer to local safety regulations on items not covered in this manual. Electrical installation, maintenance must be performed by professional / qualified personnel.











1.1 Storage and installation environment







- Handle the product with care, avoid dropping
- Avoid open flames; keep away from flammables, explosives or corrosive chemicals
- Choose a cool and dry place for storage and installation
- Avoid water and humidity ingress
- Prevent accidental access from (children and animals)
- Do not step on the product when in its in it packaging
- Do not place any foreign objects on top of the battery pack.
- Do not store the battery pack upside down

1.2 Battery safety guidelines

- Prevent from electrostatic discharge
- Wear insulating gloves when handling batteries.
- Do not energize auxiliary power during installation
- Check the polarity carefully before switching on the system
- Defected or damaged batteries shall not be charged or discharged, contact service for further advice

1.3 Warning signs and stickers

	CAUTION		Heavy Object Team lift required
	Warning Electrical shock hazard		Recycle
	Fire, Flames, Smoking Prohibited		This side up
	No stepping on		Read User manual
	Warning Hot Surface		Electrical and Electronic Equipment Waste

	Warning Electric Shock Hazard Wait for 5 min till fully discharged		Protective Earth
	Do not short circuit (cut off power)		Keep away from children
	Fragile		Do not get wet

1.4 Emergency handling

Wear personal protective equipment (PPE) such as goggles, facemask, insulated gloves and boots. Evaluate the situation before taking remedy action. When it is safe to do so, disconnect external AC or DC power connection.

Damaged or deformed battery enclosures

Pose a risk of chemical leakage (i.e. electrolyte) and internal short-circuit.



Warning

Deformed or severely damaged battery pack can lead to piercing of cell pouch (chemical leakage) or internal short-circuit (thermal runaway). The damaged battery pack can release toxic gas. Keep away from it.

In case of accidental skin contact, wash the skin thoroughly with soap and seek medical advice. For eye contact, wash under running water (~15 minutes) and require immediate medical attention.

Fire hazard

If the fire is not from the battery or has not spread to the battery, use a FM-200 or CO2 fire extinguisher to put out the fire.

If the battery pack catches fire, do not attempt to put out the fire and evacuate immediately. Seek medical advice in case of inhalation of pungent and toxic fumes.

Keep damaged batteries isolated and call your local fire department. Contact service for further support.

Water damage

Risk of electric shock and internal short-circuit. In case of splash or water spillage, when it is safe to do so, dry the product. If any part of the battery system is submerged, keep away from water.

Do not reuse the submerged battery. Contact a service for support.

1.5 System lock function

The battery system has a non-resettable function to stop operation when one or more cells in the battery system deviates from the operating region (voltage, current, temperature)

during operation.

This feature only allows for manufacturer reset.

The function of the battery system may be returned after checking that the status of the battery system complies with the battery system manufacturer manual.

2 Product description

HHS-1X(5/10/15/20)K is a plug-in energy storage system. The battery module can convert high voltage direct current (HVDC) into low voltage direct current (LVDC) through DC to DC conversion inside the battery and stores the power in batteries; it can also convert LVDC into HVDC and send the power to the grid through the inverter. This document provides product introduction, installation, commissioning, maintenance, troubleshooting, packaging and transportation information.

2.1 Product introduction

- Residential energy storage system with lithium iron phosphate (LFP) technology
- Modular design, single battery system with 5 to 20kWh (1 – 4 pcs battery)
- Single battery module is equipped with DC to DC conversion, which increases the output voltage to 350~440V
- Supports power expansion, and the single battery system with power 2.5 to 10kW
- Expandable to 40kWh (2*HHS-1X20K connected in parallel)
- Support the mixing of new and old batteries.
- Indoor or outdoor installation (IP65)
- PCS communication interface: CAN or RS485
- Bluetooth and WiFi for Mobile APP (PowerLite)
- Advanced battery management system (BMS) provides data acquisition, status monitoring and control to ensure the safe and reliable operation of the system.

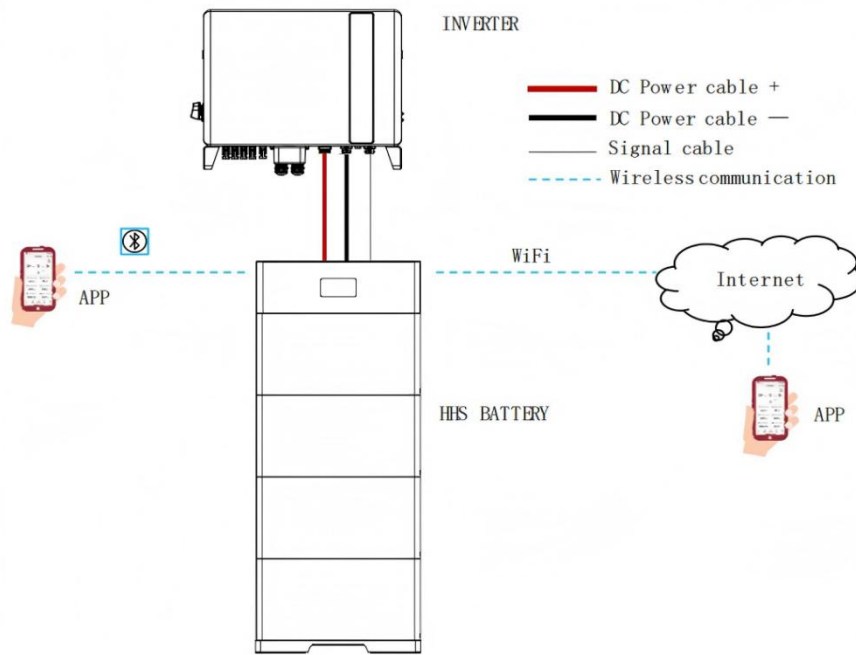

Figure 2-1-1 System topology

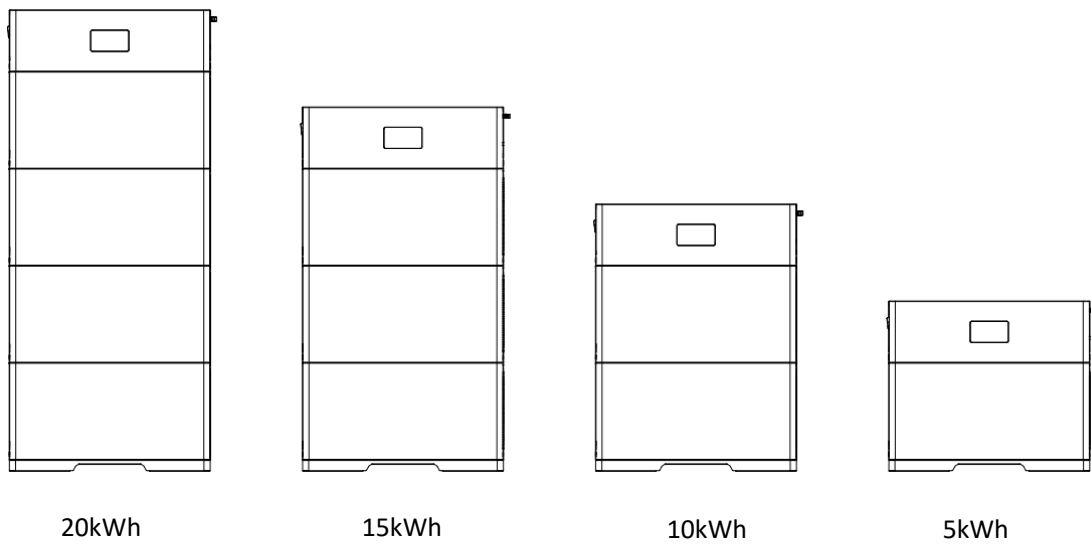

Figure 2-1-2 HHS-1X5K/10K/15K/20K configurations

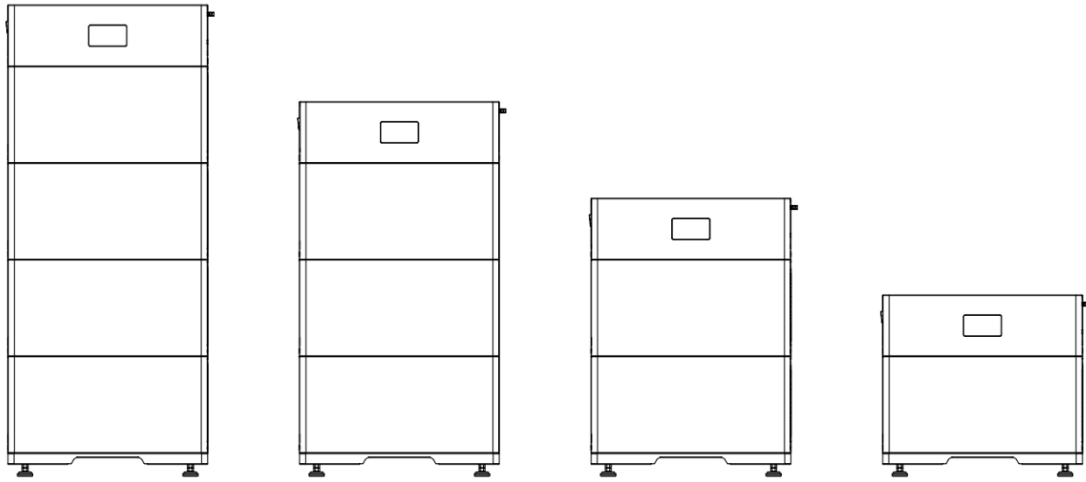

Figure 2-1-3 HHS-1X5K/10K/15K/20K configurations
(Optional version: with leveling feet)

2.2 Appearance description

- Appearance of the whole system

①	Control module
②	Battery module
③	Mounting the base

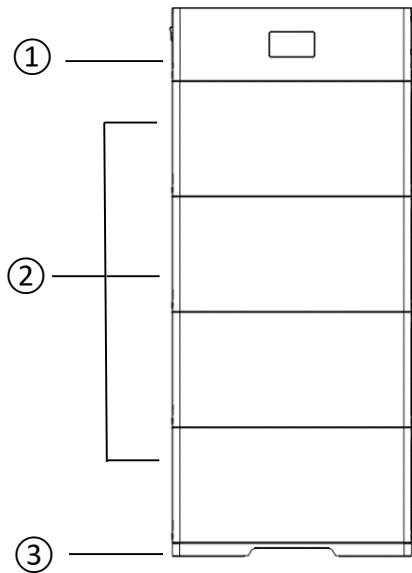

Figure 2-2-1 Appearance of the whole machine

- Control module

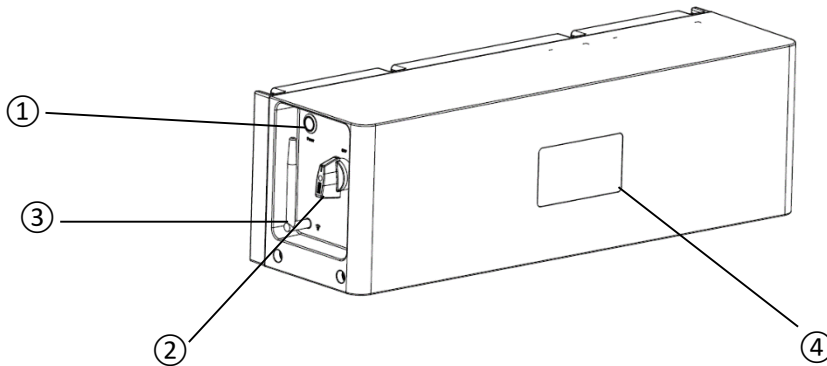

Figure 2-2-2 Left side of control module

Functional Part	Description
① Power button	Press and hold for 5s, battery power on. Press and hold for 8s, battery power off Short press, display light up.
② DC Isolator	ON: Connect the positive and negative circuits of battery, system can charge or discharge. OFF: Disconnect the positive and negative circuits of battery, system can't charge or discharge.
③ Wi-Fi antenna	-
④ Display	-

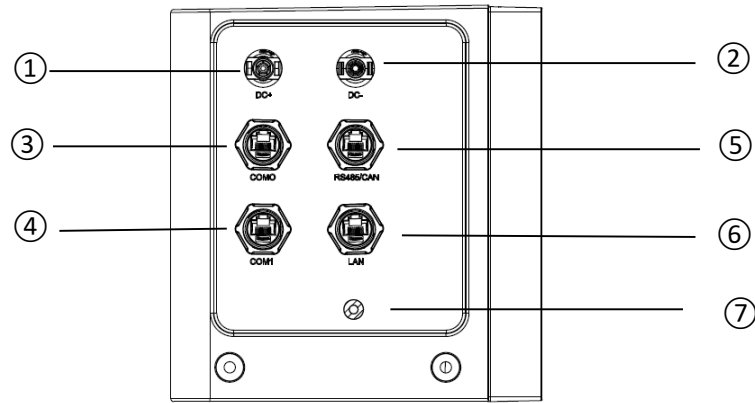

Figure 2-2-3 Right side of the control module

- ① Output Positive (DC+)
 - ② Output Negative (DC-)
 - ③ Parallel communication 0 (COM0)
 - ④ Parallel communication 1 (COM1)
 - ⑤ PCS communication (RS485/CAN)
 - ⑥ Maintenance (LAN)
 - ⑦ Protective earth (PE)
- Battery module

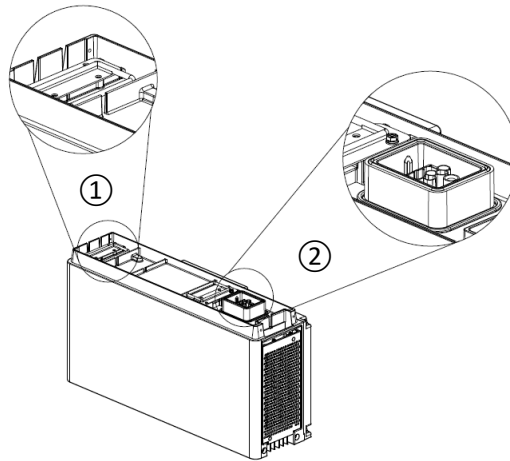

Figure 2-2-4 Structure diagram of battery module

- ① Handle ② Power/communication connector

3 Installation guide

3.1 Environmental requirements

- a. Ambient temperature: $-10^{\circ}\text{C} \sim +50^{\circ}\text{C}$ (recommended: $10^{\circ}\text{C} \sim 35^{\circ}\text{C}$ or $50^{\circ}\text{F} \sim 95^{\circ}\text{F}$).
- b. Ambient humidity: 10-95%.
- c. Altitude < 4000m.
- d. For outdoor installation
 - Avoid direct sunlight
 - Avoid rain and snow
 - Avoid location susceptible to flooding
 - Avoid areas where the battery is likely to be damaged from uncontrolled impacts (cars, motorcycles, etc...)
- e. For indoor installation
 - Local electrical standard and codes need to be followed when installing near doors, windows, driveway or other batteries
 - Do not install near any heat sources
 - Do not install in a area that contains corrosive chemicals
 - Do not install in damp or wet areas
 - Consider location equipped with ventilation fans, smoke, heat, or flammable gas detector

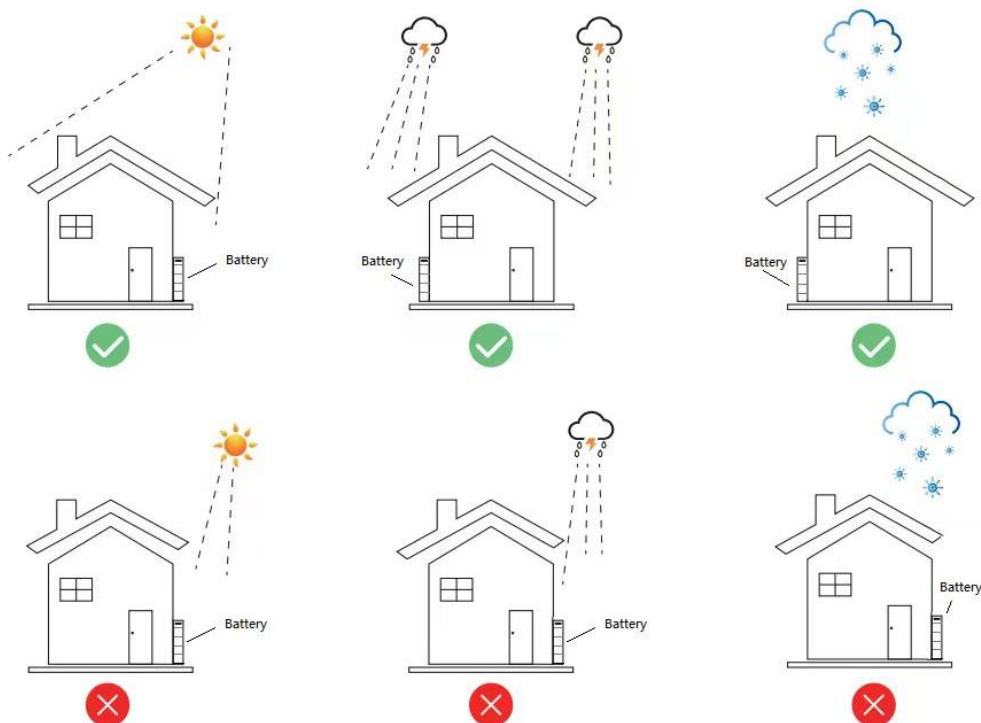



HHS-1X5K/10K/15K/20K performance degrades when ambient temperature is below 10°C (50°F) or above 40°C (104°F).

3.2 Installation physical requirements

a. Item inspection

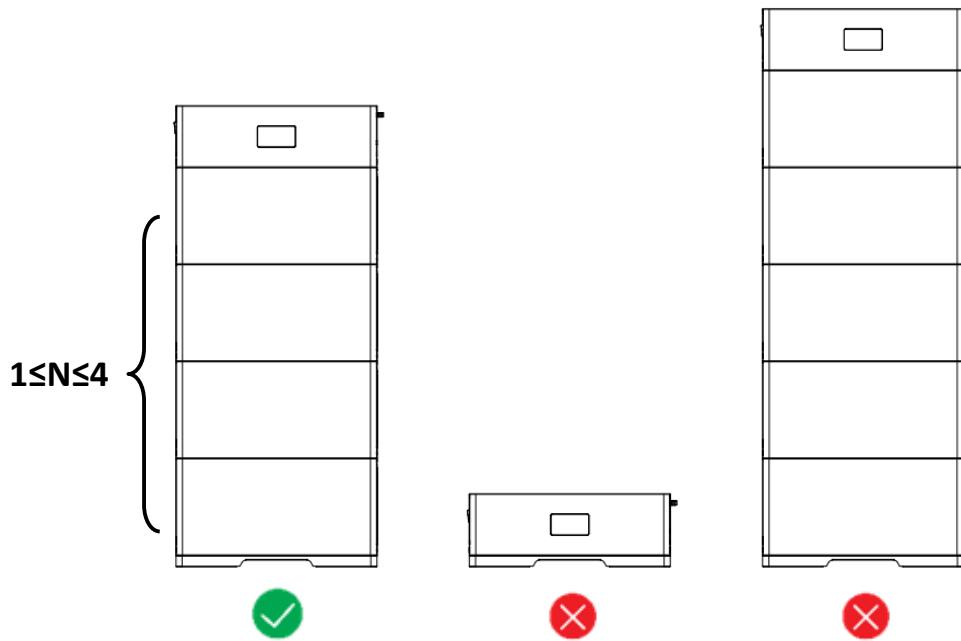

b. Installation clearance

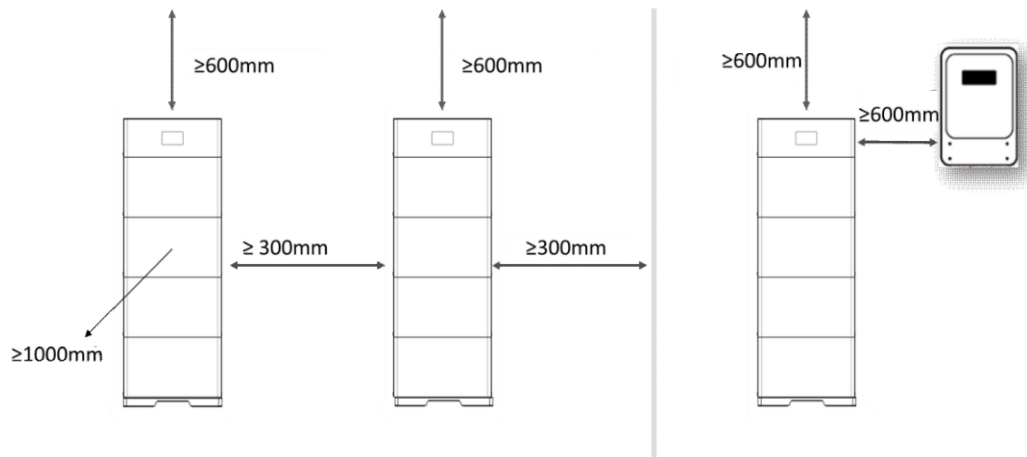

c. Level control

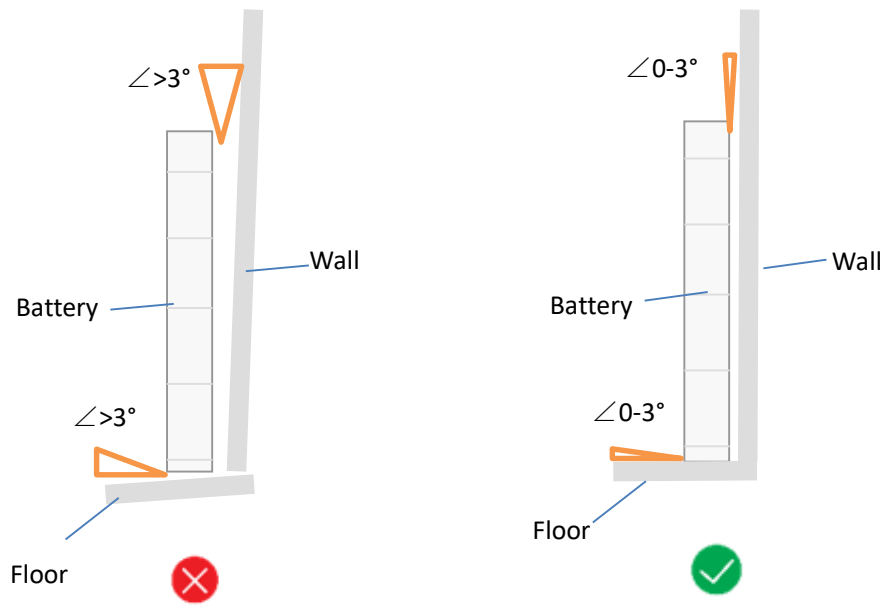

d. L-bracket fixing bolt positioning

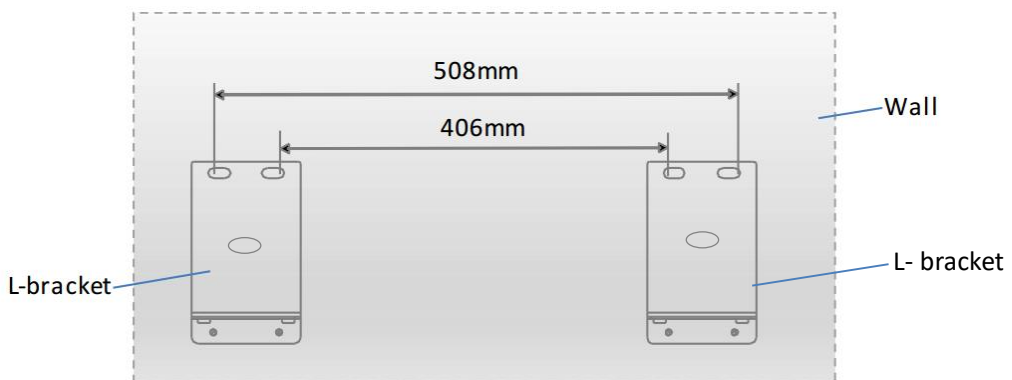

Take into account the actual surface condition before fixing the L-bracket.







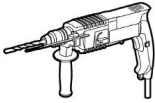
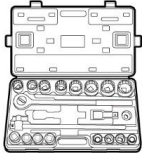

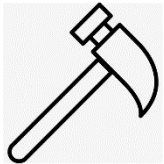

Avoid electricity wire, metal conduit or pipe inside the wall; consider using wall scanner (wall detector)

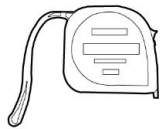
3.3 Installation



3.3.1 Installation tools





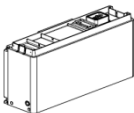

 <p>Impact drill (3/8 & 13/64 drill)</p>	 <p>Torque wrench (7/16 & 9/16 hexagonal socket)</p>	 <p>Marker pen</p>	 <p>Electric batch</p>
---	---	---	---

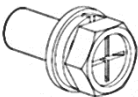

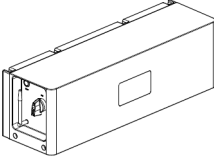
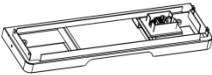

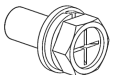
			
Hammer	Detector	Steel tape	Level ruler



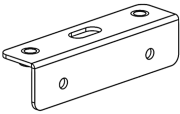

Personal Protective Equipment (PPE)			
			
Safety gloves	Safety goggles	Dust mask	Safety shoes

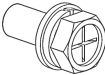
3.3.2 Packaging components

Battery Module Packaging Components		
		
Battery module X1	Screw cover X4	Fixing screws (M5*12) X4

Control Module Packaging Components			
			
Control module X1	Base X1	L-bracket X4	Fixing screws (M5*12) X12 (max)
			
Plastic expansion tube X8(max)	Self-tapping screws M6*60 X8 (max)	M6*1 8*2 large flat pad X8 (max)	Grounding Terminals X1

 <p>Angle bracket X4 (max)</p>	 <p>Screw cover X4</p>	 <p>Fixing screws (M6*14) X8 (max)</p>	 <p>User manual X1</p>
 <p>Leveling foot X4 (Optional)</p>			

Cable kit Packaging Components			
 <p>Positive wire harness X1</p>	 <p>Negative wire harness X1</p>	 <p>PCS-RS485/CAN communication cable X1</p>	 <p>120ohm resistor X1</p>

3.4 Installation steps

a. Place the base

- ① Take the control module and base module out of the carton and put them side by side.

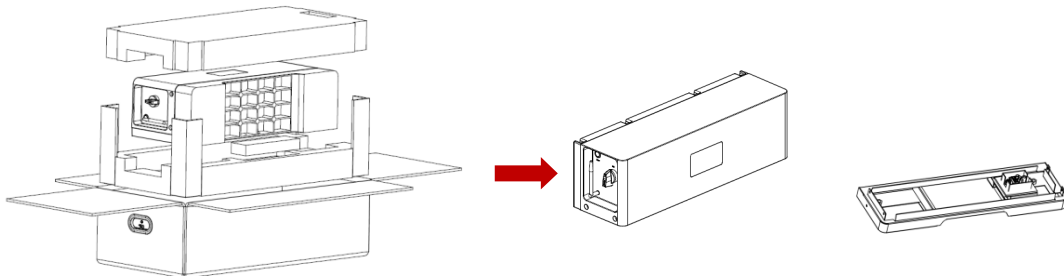

- ② Installation of the leveling feet (If it is a standard version, please ignore this step)

Assemble the leveling feet to the base, ensuring the locking nut of feet is flush with the bottom surface of the base.

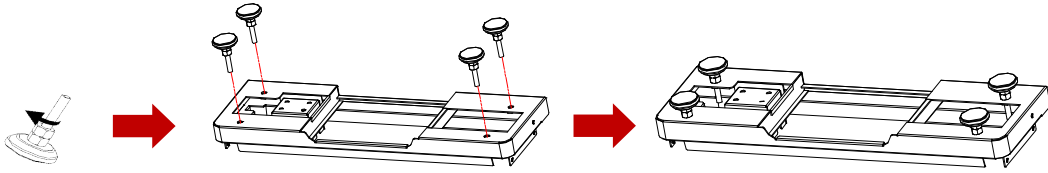

Note: Before installing the feet, adjust feet's nut until it seats against the fixed nut.

③The base module should be placed on a level ground, parallel to the wall. The clearance to the wall should be 35mm .

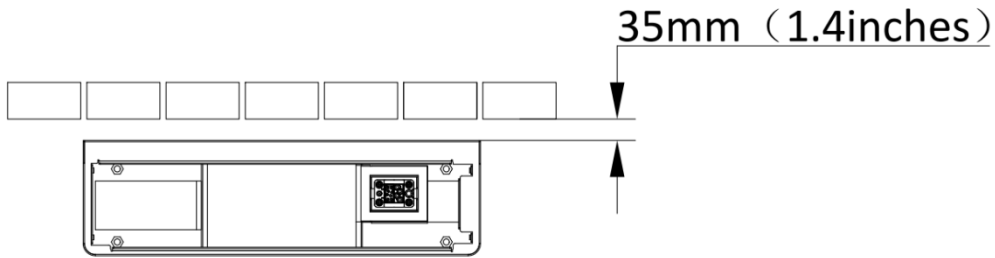

④Rotate the locking nuts of feet with a wrench, until the leveling bubble of level ruler is centered. Then tighten adjusting nuts of feet upward until they fully contact the base, and securely lock it in position. (If it is a standard version, please ignore this step)

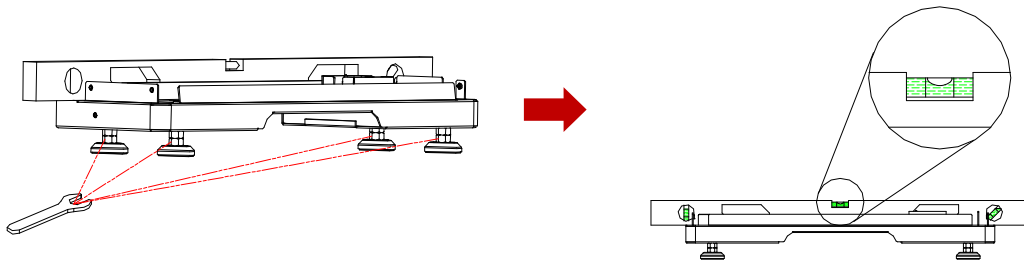

Install the leveling feet must installed wall-against bracket (angle bracket + L-bracket)

b. Install the angle bracket

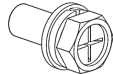
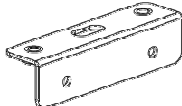
Fixing screw	M5*12	4 pcs	
Angle bracket	-	2 pcs	

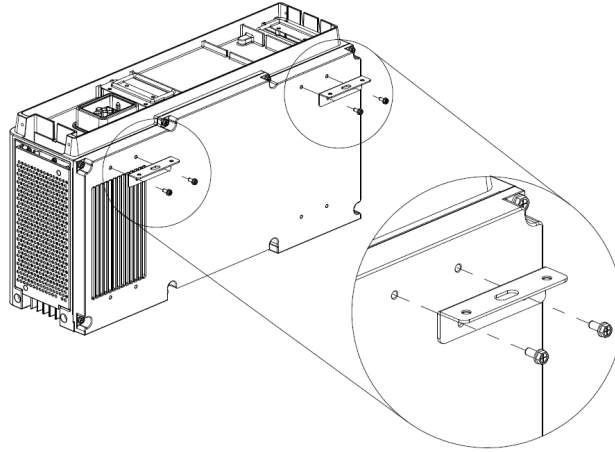

Refer to the following for the recommended the wall mounting assembly (angle bracket + L-bracket) installation:

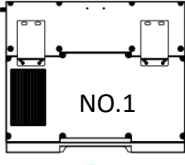
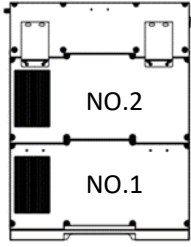
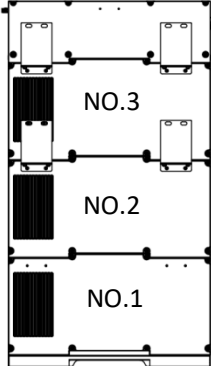
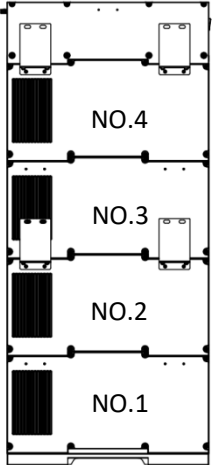
 <p style="text-align: center;">✓</p>	 <p style="text-align: center;">✓</p>	 <p style="text-align: center;">✓</p>	 <p style="text-align: center;">✓</p>
<p>1 mounting assembly on Batt. No.1</p>	<p>1 mounting assembly on Batt. No.2</p>	<p>2 pcs mounting assembly on Batt. No.2 Batt. No.3</p>	<p>2 pcs mounting assembly on Batt. No.2 Batt. No.4</p>

c. Stack battery module



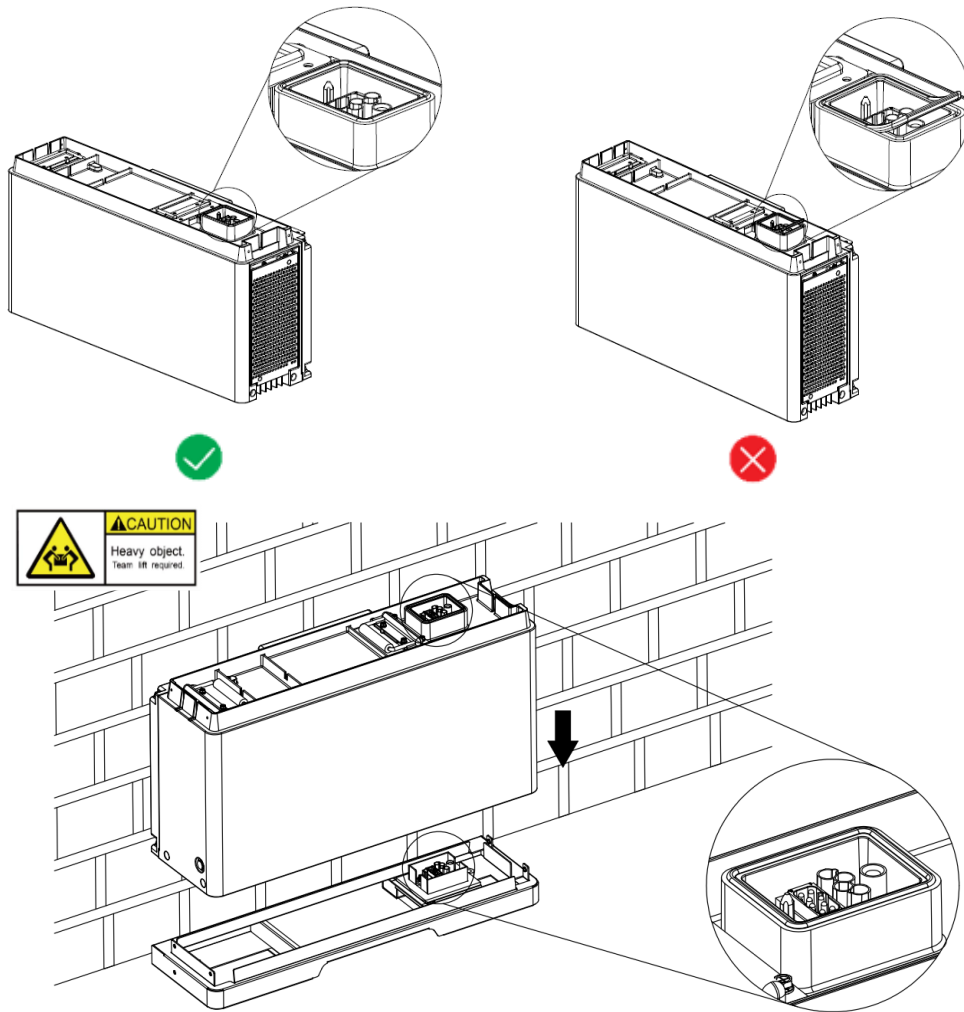

Before stack battery module, check that the terminal sealing ring is well fixed.



Unit weights 50kg (110.2lbs). Two or more people are necessary. Align the connector side first, then stack gently to avoid damaging the connector!

When fixing the battery to a wall, ensure it is securely mounted. Due to the battery's top-heavy design, proper support is essential to prevent tipping or damage. This may require locating a stud in a timber-framed wall for structural support or installing a stronger wall covering.

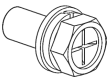
Fasten the installed battery module

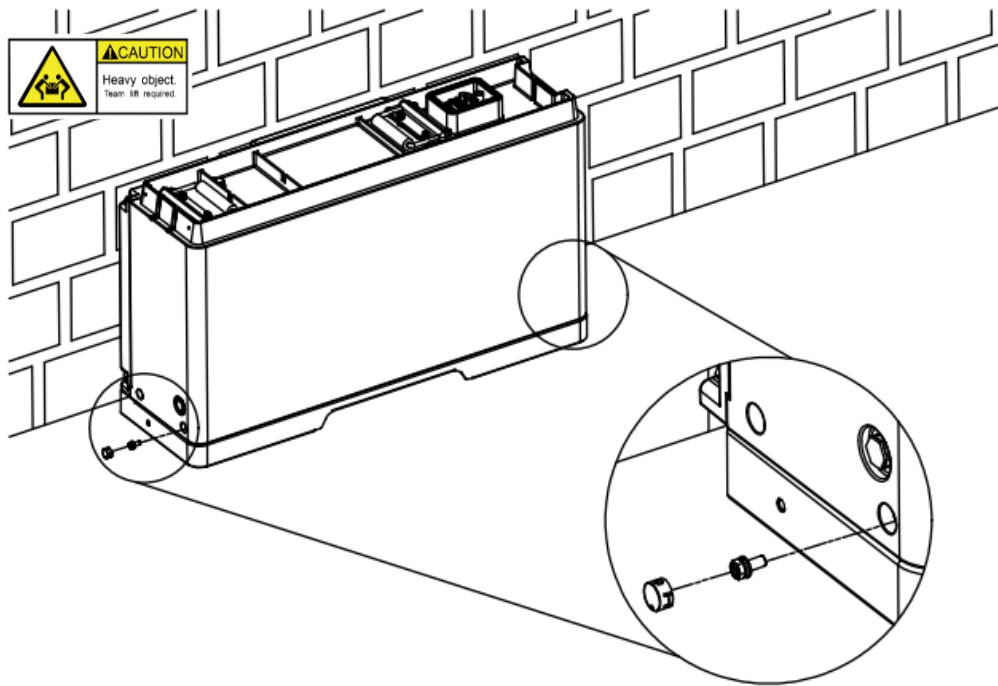

Fixing screw	M5*12	4 pcs	
Screw cover	plastic	4 pcs	

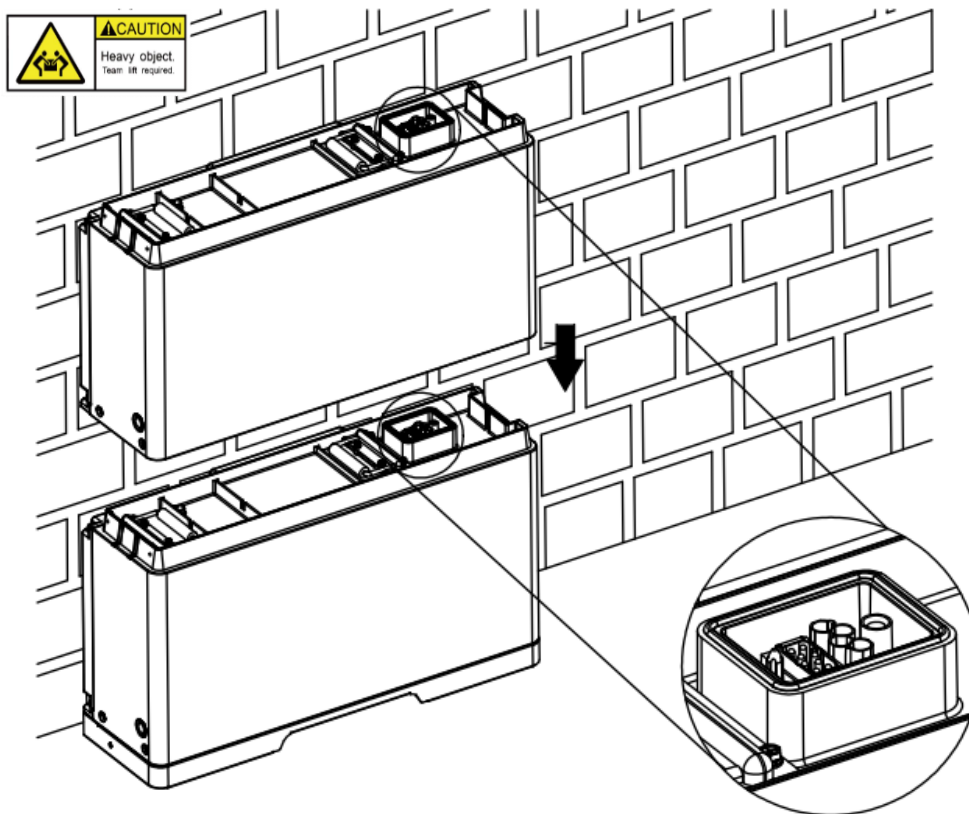

d. Adding additional battery module

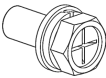

Fasten the stacked battery module

Fixing screw	M5*12	4 pcs	
Screw cover	plastic	4 pcs	

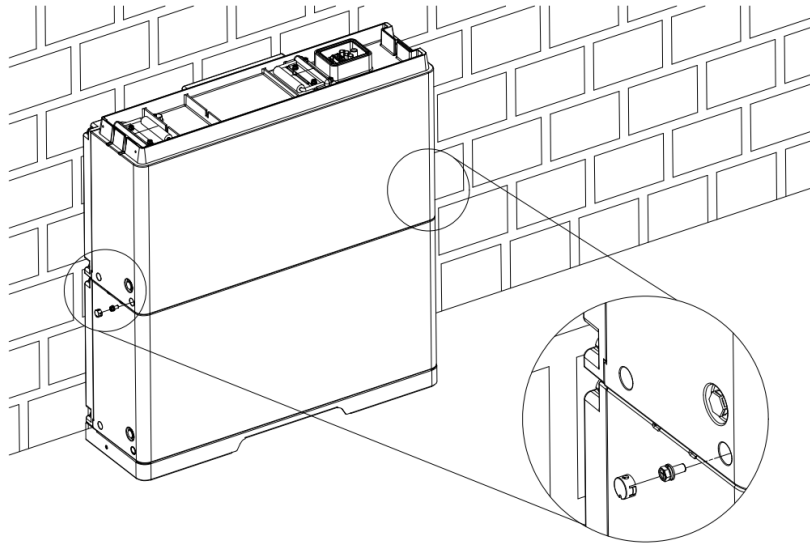

e. Install L-bracket

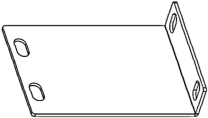
L-bracket	-	2 pcs	
-----------	---	-------	---

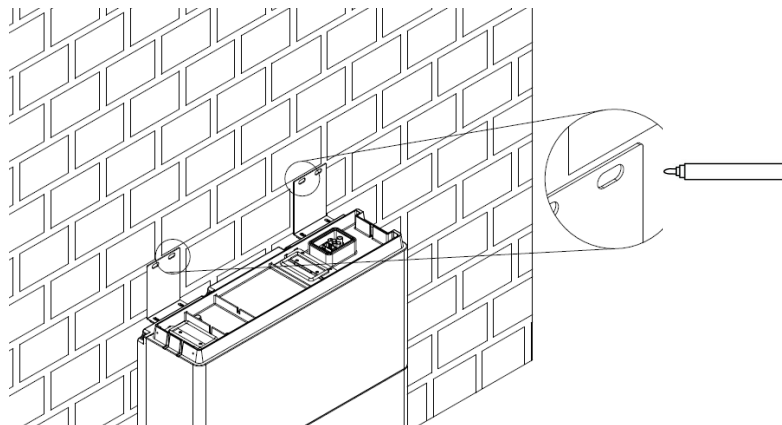

① Mark the screw position

Place the L-shaped bracket against the wall on the L-bracket and mark the drilling point



② Drilling (for concrete or brick wall) and fixing the L-Bracket to the wall

Use PE bag (from the product packaging) to prevent falling debris.

Self-tapping screws	M6*40	4 pcs	
Plastic expansion tube	-	4 pcs	
Large flat pad	M6	4 pcs	

Note:

1. For wooden wall, use the self-tapping screw and penetrate the wooden wall at least 38mm. Use M6*40 4pcs self-tapping screws to drill directly into the stake.
2. For concrete or brick wall, use Impact drill (with 13/64 bit) to drill the holes and insert the plastic expansion tubes. The recommended drilling diameter is 9mm and the drilling depth of approximately 45mm.

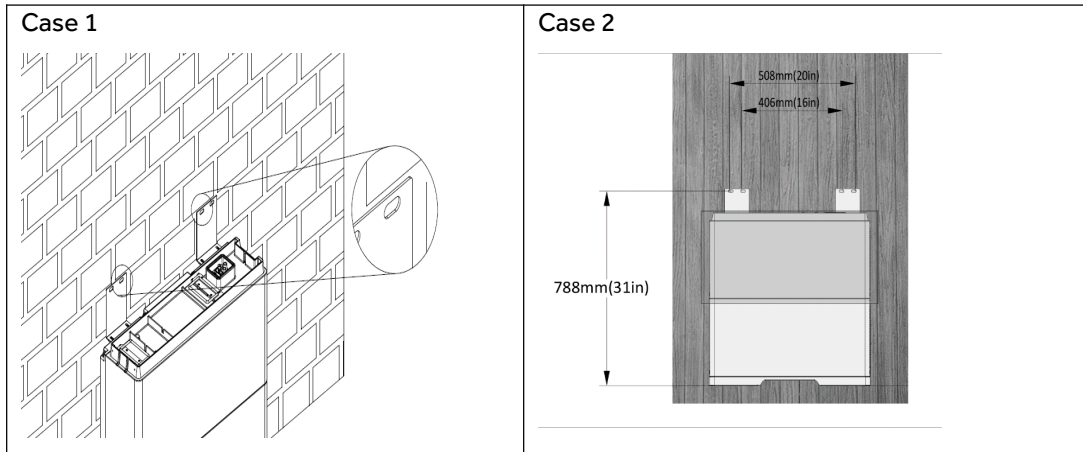

Make sure the connector is clean from debris.

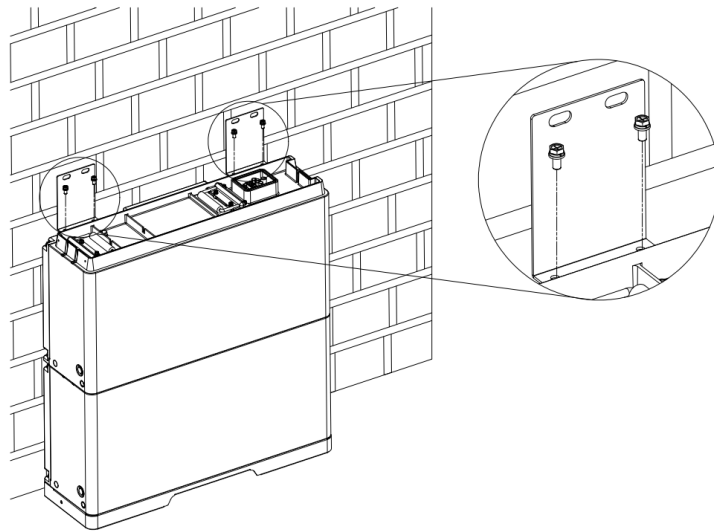

③ L-shaped bracket assembly

Hex screw	M6*14	4 pcs	
-----------	-------	-------	---

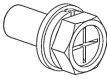

f. Stack additional battery modules (up to 4 battery modules in total)

Fasten the stacked battery module

Fixing screw	M5*12	8 pcs	
Screw cover	plastic	8 pcs	

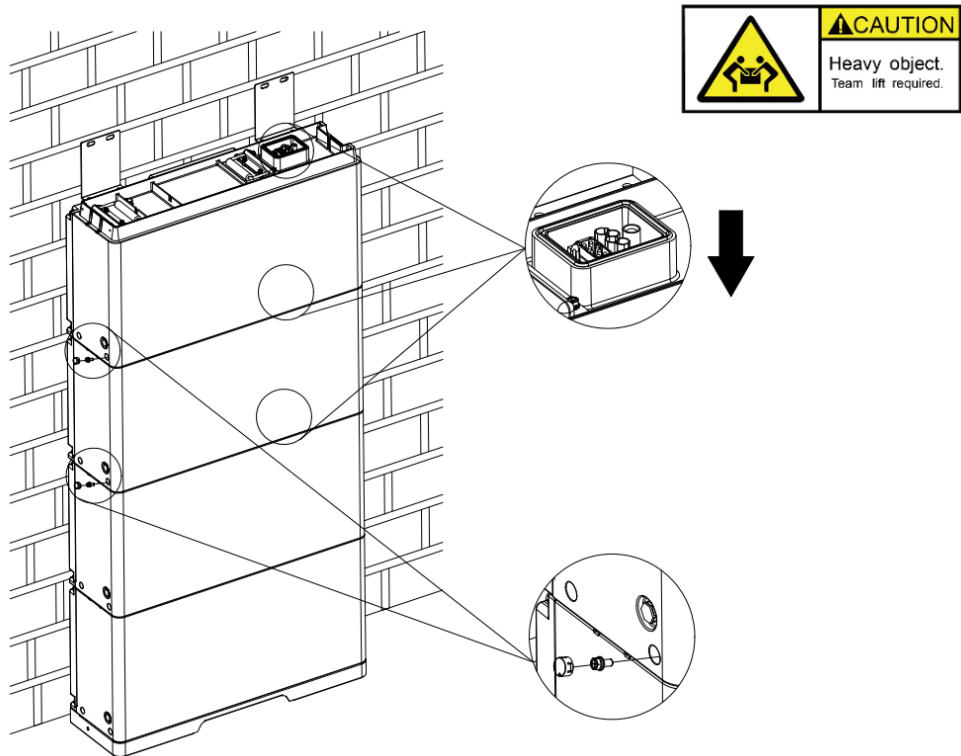

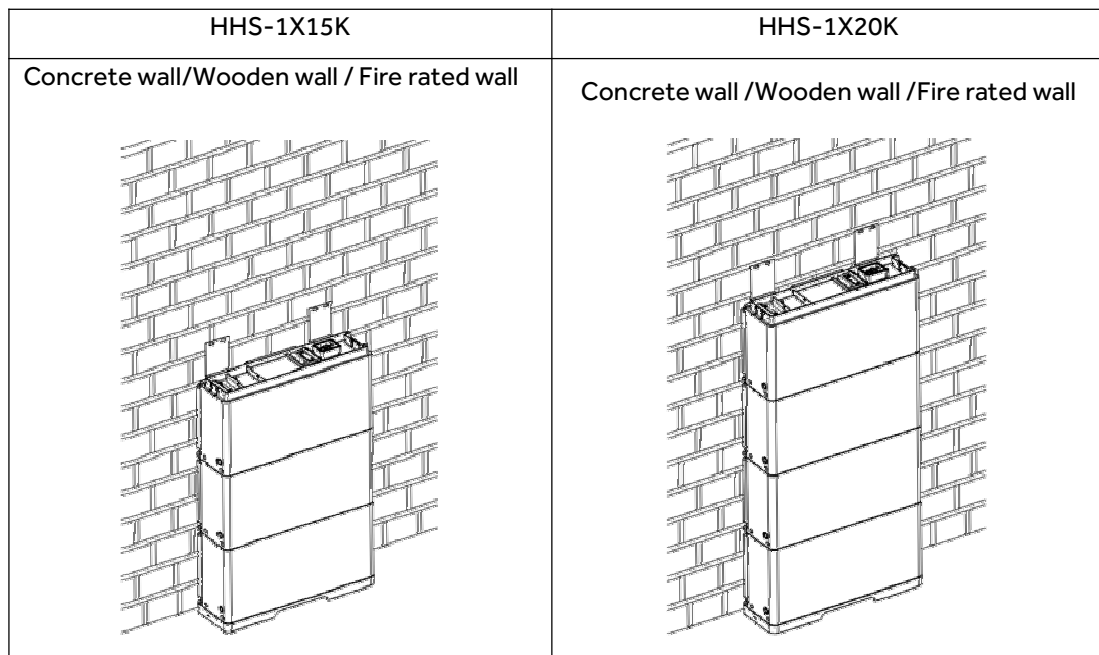
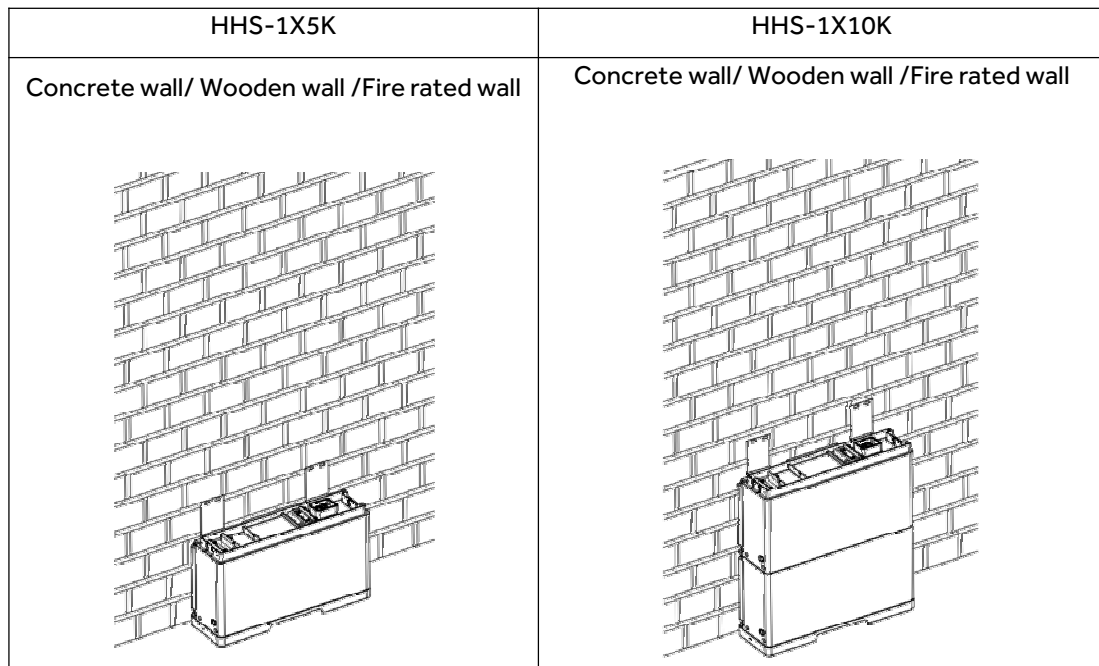

g. The overall bracket completes the installation position arrangement

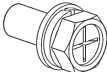

h. Control module installation

①Fasten the stacked battery module

Fixing screw	M5*12	4 pcs	
Screw cover	plastic	4 pcs	

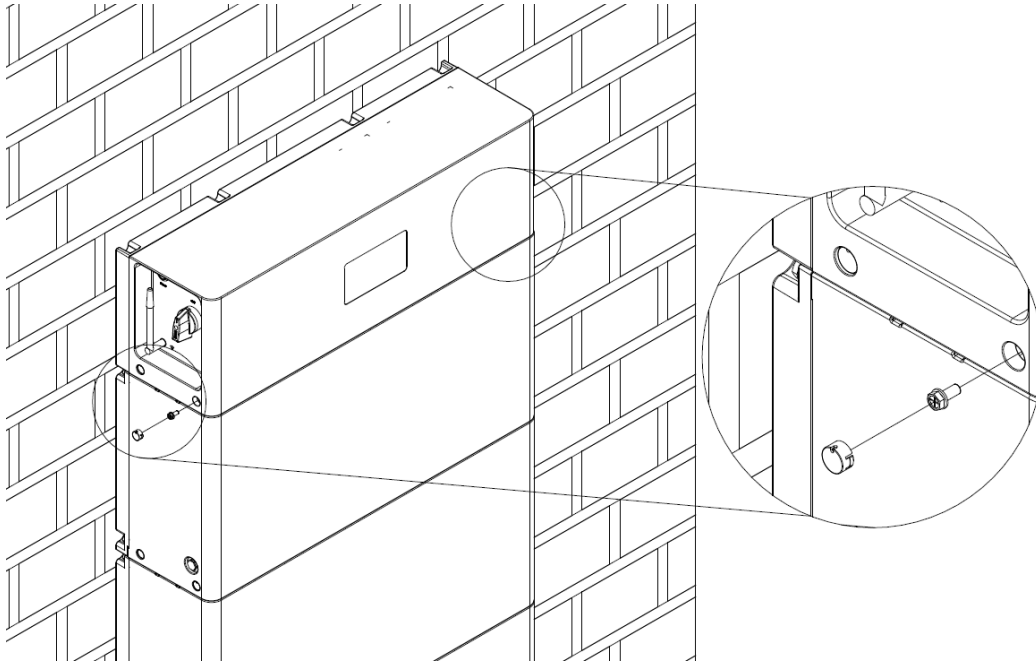

② Check model

Tick the nameplate model according to the number of installed battery modules:

5kWh: HHS-1X5K	10kWh: HHS-1X10K
15kWh: HHS-1X15K	20kWh: HHS-1X20K

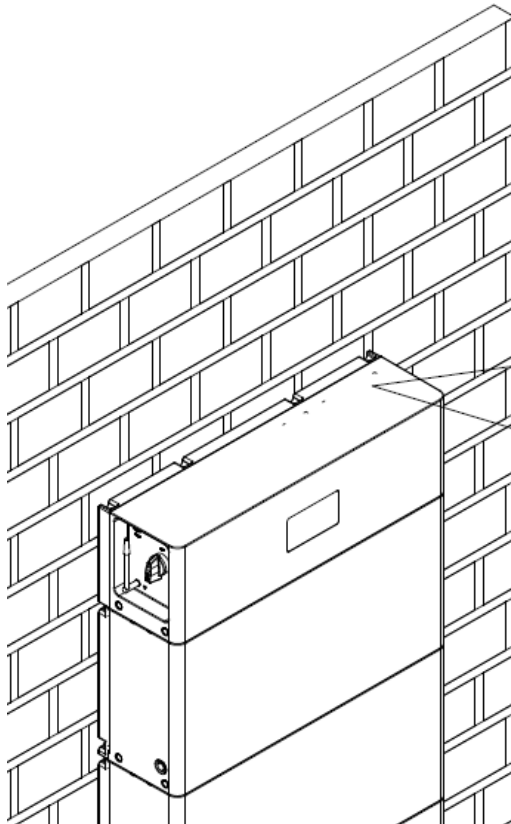

Haier Rechargeable Lithium Iron Phosphate Control Module				
Model	HK6050P03-H			
Operating Voltage	230-550V a.c.			
Max. Current	50A			
Rechargeable Lithium Iron Phosphate Battery System				
Model	<input type="checkbox"/> HHS-1X5K	<input type="checkbox"/> HHS-1X10K	<input type="checkbox"/> HHS-1X15K	<input type="checkbox"/> HHS-1X20K
Battery Type	#P#1/16/1/1/10	#P#1/16/1/1/13	#P#1/16/1/1/13	#P#1/16/1/1/10
	100Ah/20kWh	100Ah/20kWh	100Ah/20kWh	100Ah/20kWh
Rated Capacity/Energy	100Ah/20kWh	200Ah/40kWh	300Ah/60kWh	400Ah/80kWh
Rated Power	2.5kW	5kW	7.5kW	10kW
Max. Charge/Discharge Current	6A/6.5A	12A/12A	16A/16.5A	24A/26A
Nominal Voltage/Operating Voltage	51.2V/48V/48V d.c.			
Enclosure Type	IP55			
Protective Class	I			
Ambient Temperature	-10°C ~ 50°C (Charge) / -20°C ~ 50°C (Discharge)			
Max. Short Circuit Current	100A/100A			
Qingdao Natul Energy Technology Co., Ltd. Room 303, Entrance 1, No.4 Building, Lun-Gui Entrepreneurship Center, Phase 1, No. 7, Keyi Road, Anshan District Office, Jinyi District, Qingdao, Shandong, China www.natu-energy.com MADE IN CHINA				

i. Installation accomplish

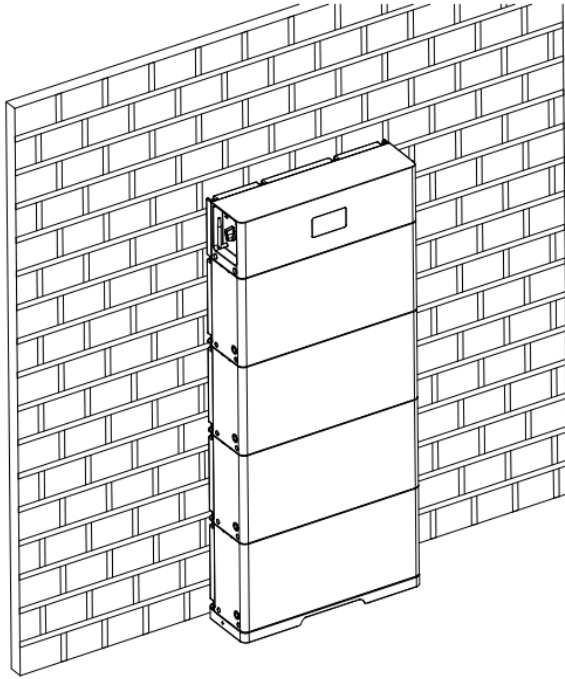

4 Electrical connections



Do not power on the system during electrical connection.

4.1 Grounding instructions

The recommended grounding cable specifications are as follows.

Ground cable	6mm ² /yellow-green
Ring terminal	M5
Screw	M5

Prepare and install the ground cable:

- a. Select a ground cable with appropriate length and recommended specifications.
- b. Strip one end of the ground cable to a suitable length.
- c. Use proper tooling to crimp the ground cable with OT terminal.
- d. Connect the OT terminal to the control module with M5 Screw.
- e. Crimp another end of the ground cable and connect to the ground point.

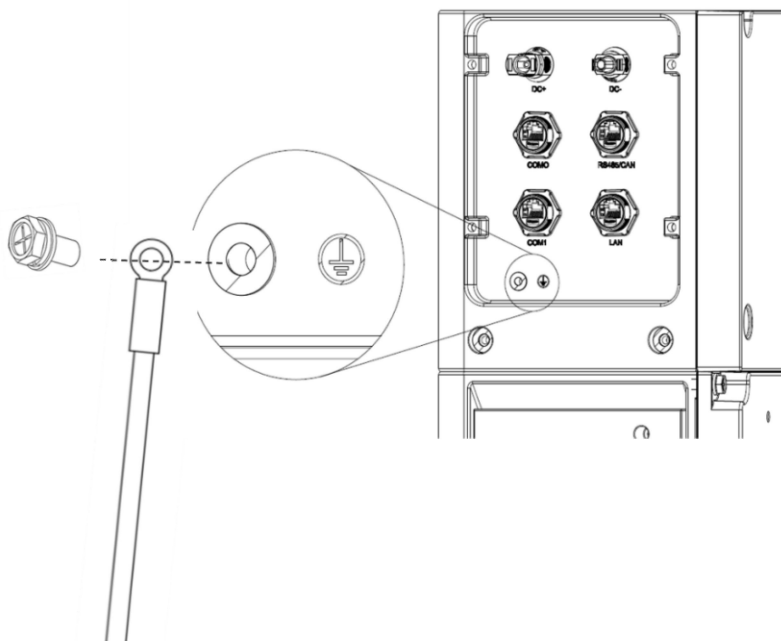
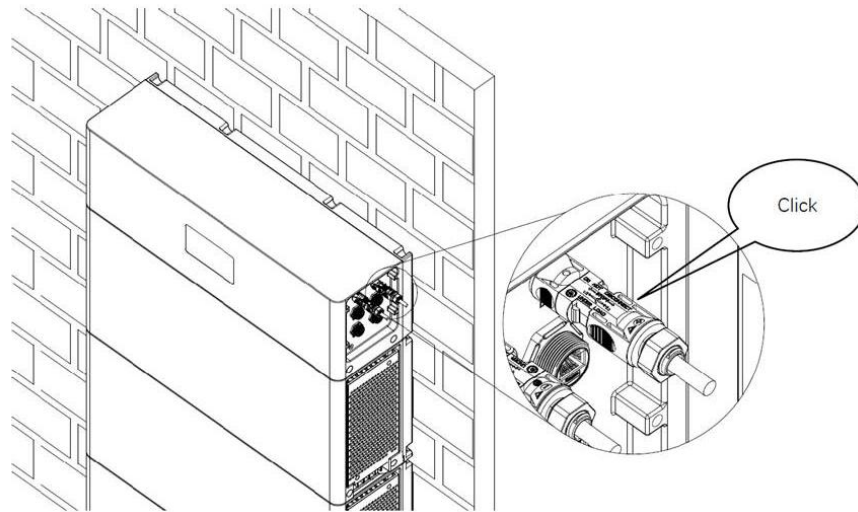
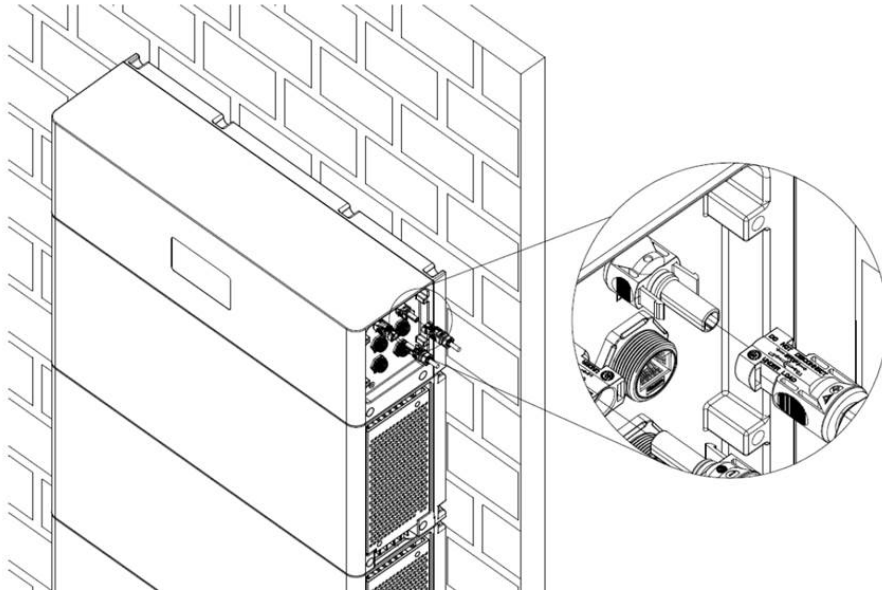

Figure 4-1-1 Schematic diagram of equipment grounding

4.2 Power connector installation

1. Power cable installation

- a. Connect the cable DC terminal to the control module as shown below, and push it until you hear one "Click" sound, which proves the fastened connection.



b. When pulling out the DC terminal, press the clips on both ends of the connector and then pull it out, as shown in the figure.

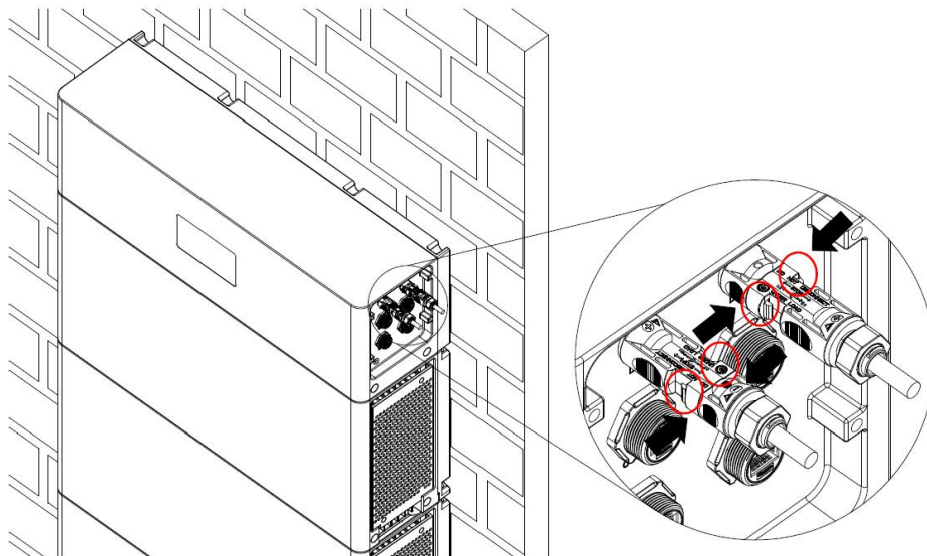

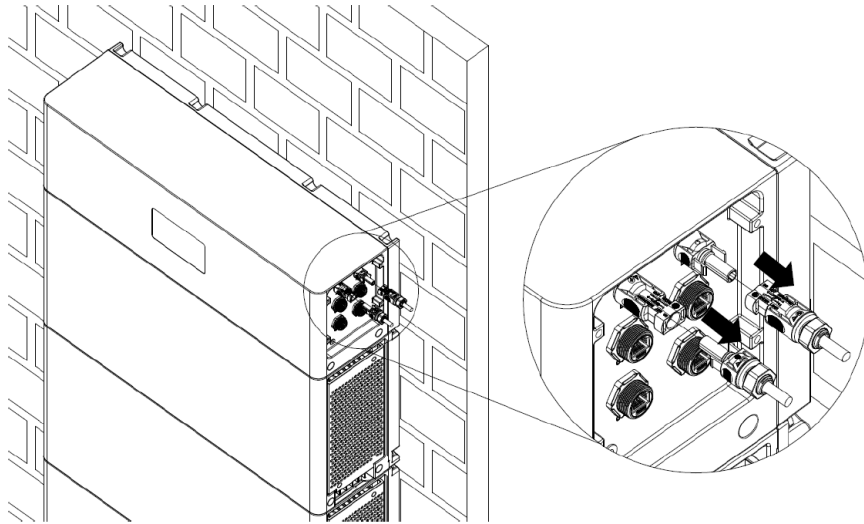

2. Communication cable installation

a. Connect the communication cable to the control module as shown below. After insert terminal into 'RS485/CAN' port, rotate locknut to secure connection.

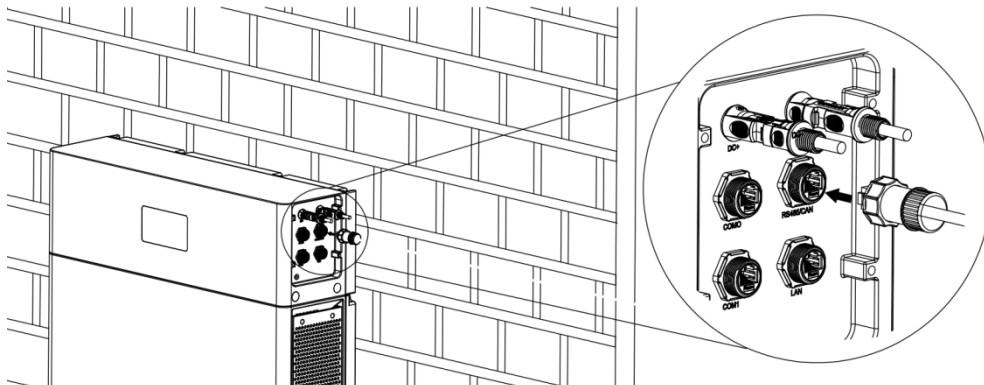

Note: If the battery system fails to communicate with the inverter, verify the pin out compatibility between both devices.

b. Ensure stable communication, 120ohm resistor should be installed on COM1 port of control module.

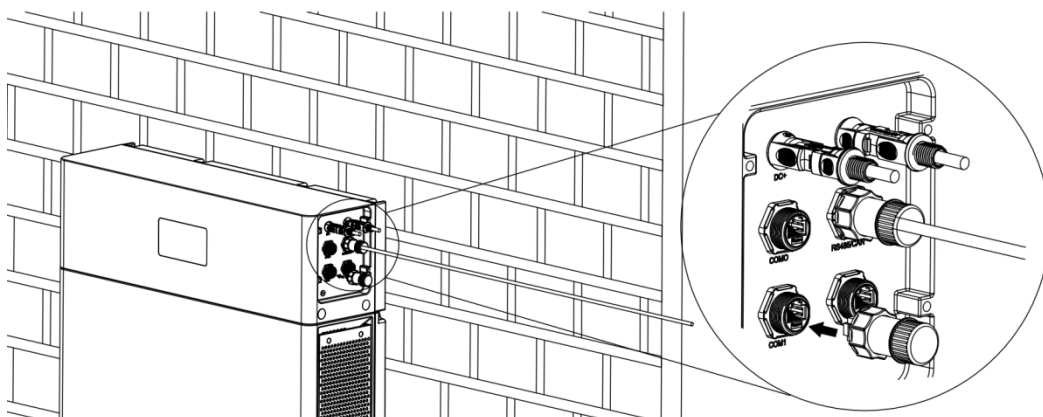

4.3 Cable connection



All installation work and circuit protection must comply with AS/NZS 3000:2018 and AS/NZS5139:2019 and the local electrical safety regulations.

4.3.1 External DC Circuit breaker for HHS Installation

Each HHS battery stack shall be protected by a double-pole DC circuit breaker in accordance with the specifications provided in the table below.

Voltage	> 600V
Current	Battery stack MCB = 32 A, Inverter MCB = 63A
Operating temperature	Contains the scope [-20,50] °C
Connection cable specifications	10mm ²

For HHS battery parallel connections, it must consider the effect of cable lengths, as the cable size indicated in the table above may be insufficient to maintain acceptable voltage drop requirements.

4.3.2 Wiring Connections for HHS

Haier Inverter and single HHS battery stack (See Figure 4-3-2a)

Connection Description	Cable Size	Circuit Breaker Type
Haier inverter DC output → Inverter circuit breaker	10mm ²	63A Double pole DC
Inverter circuit breaker → Battery (1) circuit breaker → Battery terminals	10mm ²	32A Double pole DC

Goodwe EHB Inverter and single HHS Battery stack (See Figure 4-3-2c)

Connection Description	Cable Size	Circuit Breaker Type
Goodwe EHB Inverter DC output to Battery (1) then to Battery(2) circuit breaker	10mm ²	built-in Double pole DC
Battery (1) circuit breaker to Battery terminals	10mm ²	32A Double pole DC

Haier Inverter and Battery Stacks in Parallel (See Figure 4-3-2b)

Connection Description	Cable Size	Circuit Breaker Type
Haier inverter DC output → Inverter circuit breaker	10mm ²	63A Double pole DC
Inverter circuit breaker → Battery (1) circuit breaker → Battery terminals	10mm ²	32A Double pole DC
Inverter circuit breaker → Battery (2) circuit breaker → Battery terminals	10mm ²	32A Double pole DC

Goodwe EHB Inverter and Battery Stacks in Parallel (See Figure 4-3-2d)

Connection Description	Cable Size	Circuit Breaker Type
Goodwe EHB Inverter DC output to Battery (1) then to Battery (2) circuit breaker	10mm ²	built-in Double pole DC
Battery (1) circuit breaker to Battery terminals	10mm ²	32A Double pole DC
Battery (2) circuit breaker to Battery terminals	10mm ²	32A Double pole DC

Installation considerations

When two 10mm² DC cables are paralleled into a single breaker terminal, use bootlace ferrules. Ferrules prevent strand splaying, ensure a solid low-resistance connection, and reduce the risk of hotspots, arcing, or fire. This complies with AS/NZS 3000 requirements for fully secured and correctly terminated stranded conductors. Use a dual-entry ferrule (20mm²) and crimp with a ratchet tool for a safe, compliant termination.

Safe Operation

1. When using batteries in parallel for the first time, always turn on the circuit breaker switch before switching on the battery itself. This prevents a sudden inrush of current from damaging the inverter.

2. WARNING - PARALLEL BATTERY OPERATION

Before connecting batteries in parallel, make sure all batteries have the same state of charge (SOC).

If the SOCs are not equal:

1. Keep the inverter circuit breaker (MCB) closed.
2. For each battery stack:
 - Close the battery circuit breaker (MCB).
 - Turn ON the power button.
 - Turn ON the DC isolator.
3. Set the inverter to Self-Use work mode:
 - Select Time of Use settings.
 - Set the maximum charge current for the inverter, and SOC to 100%.
 - Enable Allow Grid Charging.
 - Configure a 10 -hour charging window.
 - Both battery stacks will equalize automatically through charging.
 - For initial commissioning, it is recommended to charge the batteries to 100% SOC.
4. Once SOCs are equalized, the system will operate in parallel.
5. Once both battery stacks are fully charged, select the required work mode for the inverter.

4.3.3 Communication Interface Definition of HHS Battery system



Refer to user manual for inverter connection.

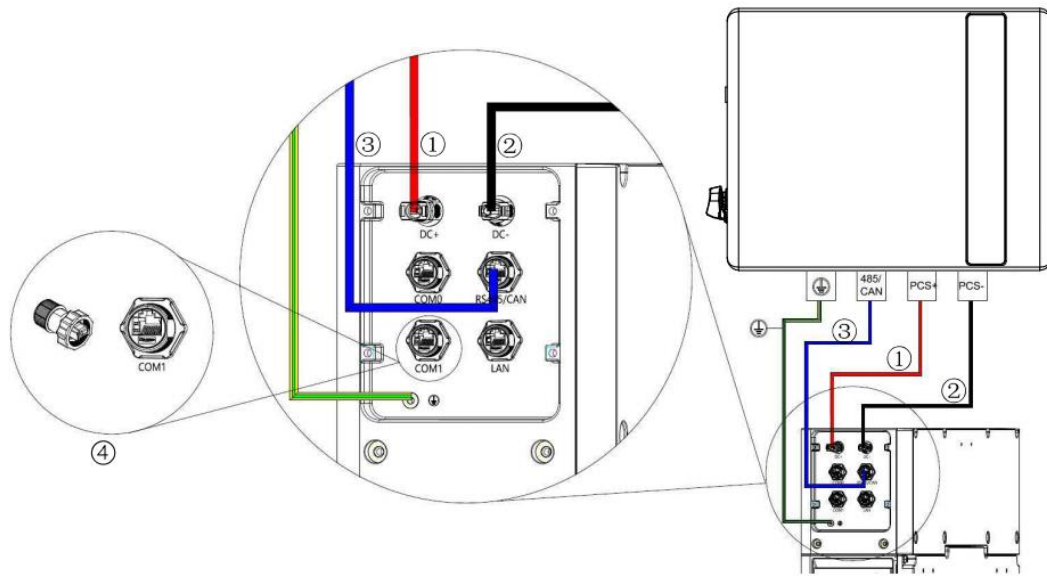

Figure 4-3-1 Cable diagram of single HHS Battery system



120ohm Resistor shall be installed on COM1 port (To eliminate signal reflections in communication cables.)

RS485/CAN port pin definition of the control module:

Color	Port	Pin	Function
Orange-white		1	RS485A
Orange		2	RS485B
Green- white		3	NC
Blue		4	CANH
Blue- white		5	CANL
Green		6	NC
Brown-white		7	Wakeup+(5VDC)
Brown		8	Wakeup-

4.3.4 Parallel HHS Battery System



Pictures are for illustration only and do not advise circuit protection polarity.

Please refer to the table on page 25 for cable and circuit protection sizing.

4.3.4.1 Haier HH3P Inverters 1 Stack solution and single HHS battery stack

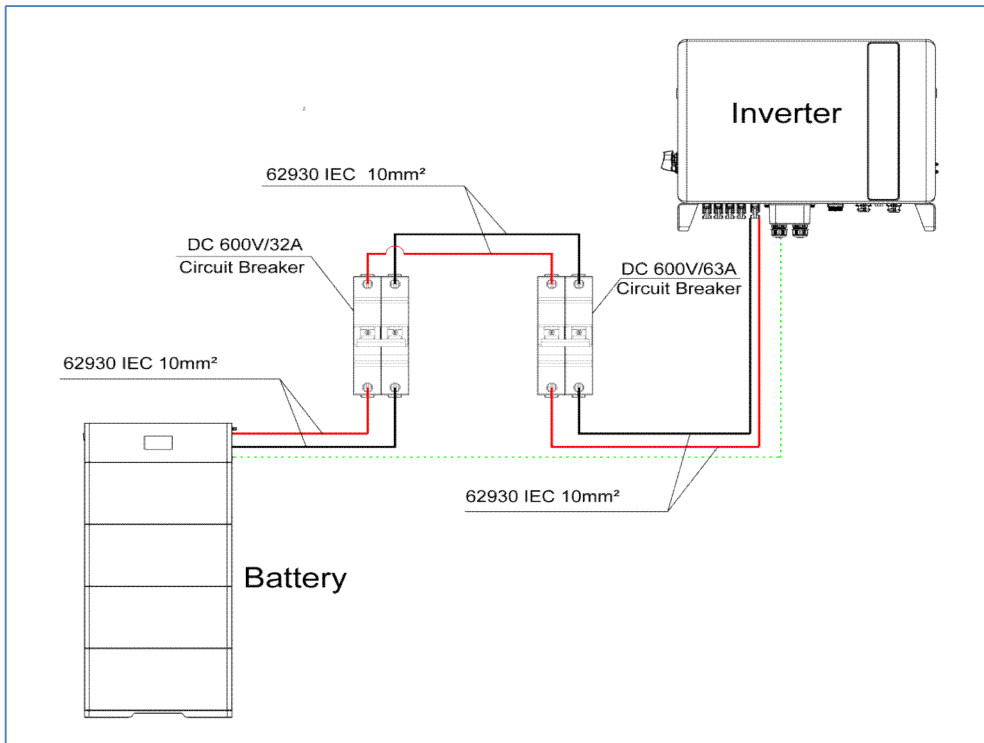

Figure 4-3-2a Haier Inverter and single HHS Battery stack wiring diagram

4.3.4.2 Haier HH3P Inverters and HHS battery stacks in parallel

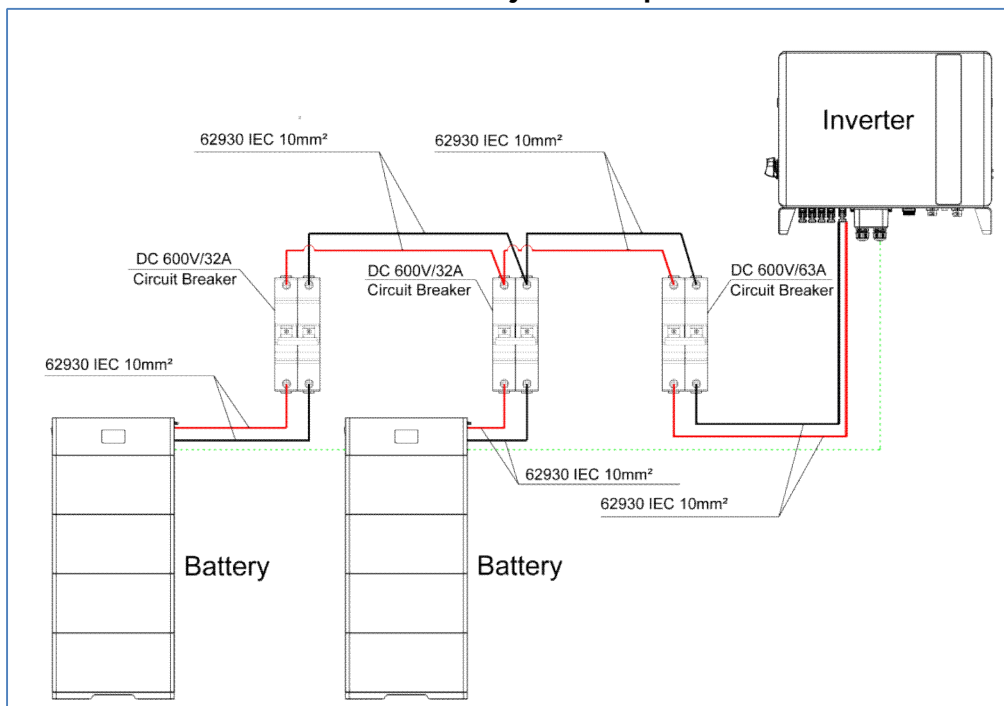

Figure 4-3-2b Haier Inverter and 2 HHS Battery stacks wiring diagram

4.3.4.3 Goodwe Inverter and single HHS battery stack

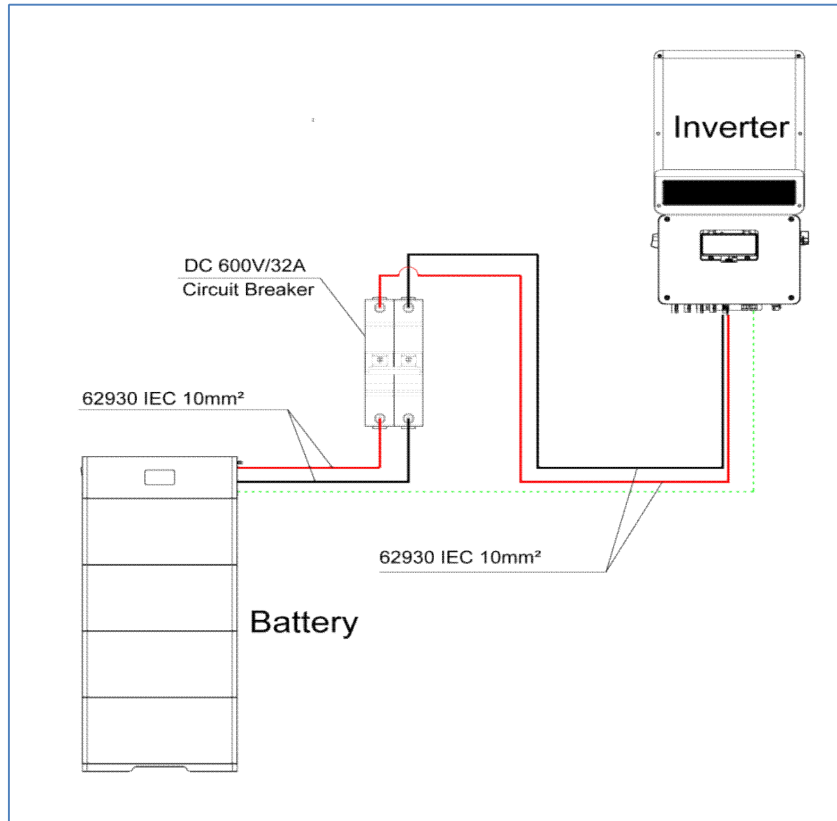

Figure 4-3-2c 1 Goodwe Inverter and single HHS battery stack

4.3.4.4 Goodwe EHB Inverters and HHS battery stack in parallel wiring diagram

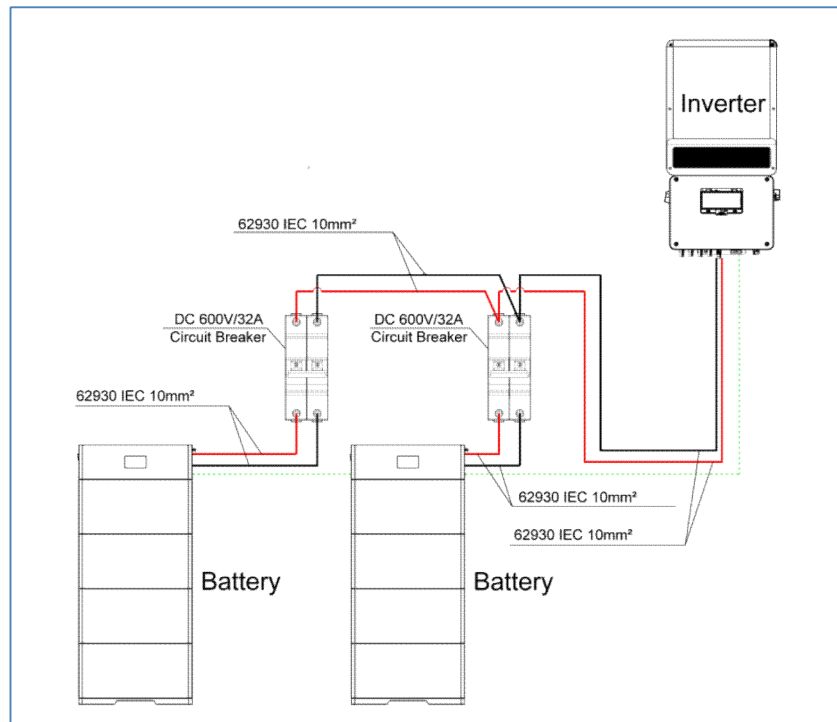
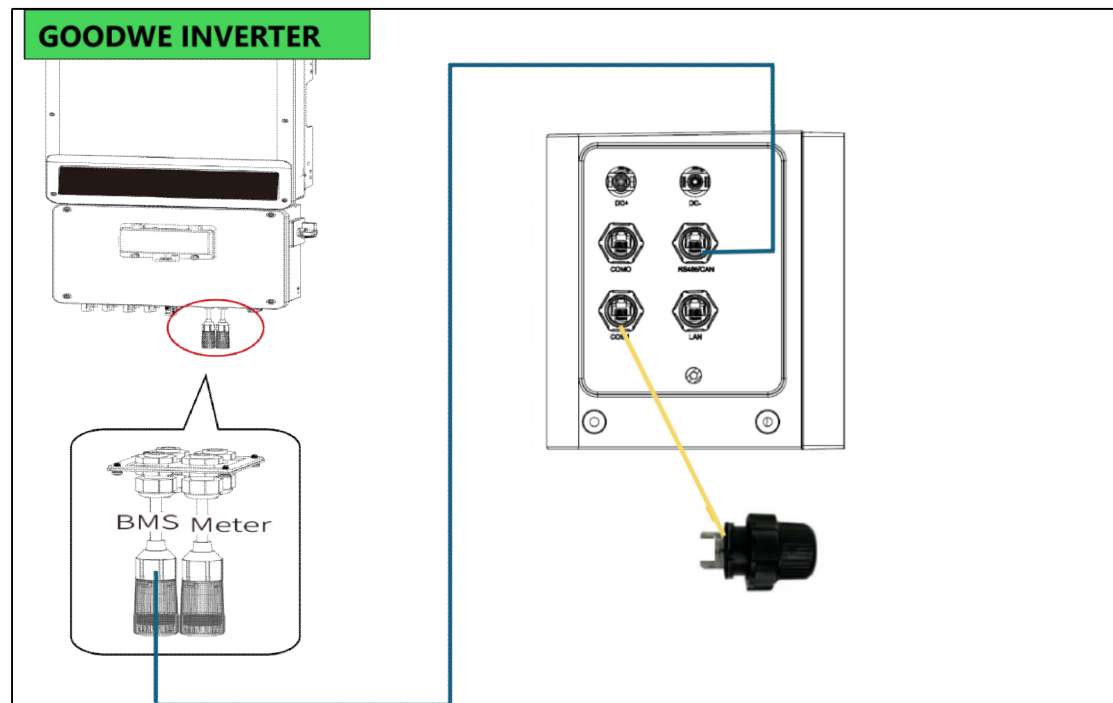
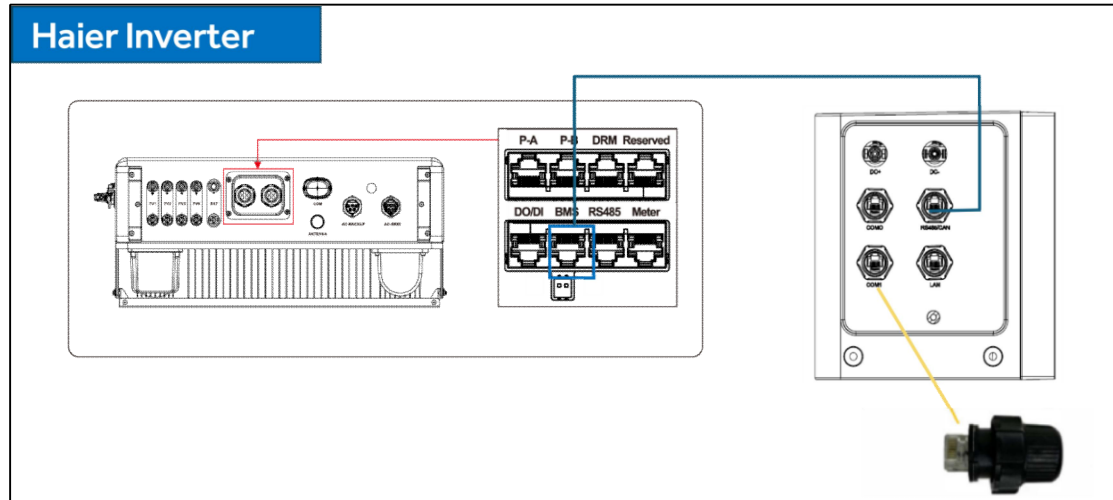
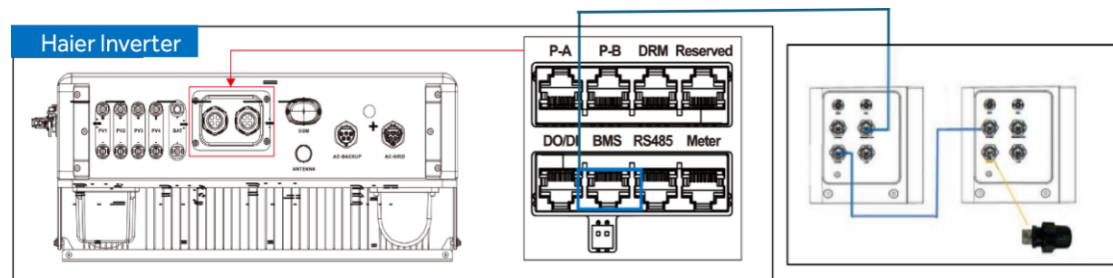

Figure 4-3-2d Goodwe Inverter and HHS battery stack in parallel wiring diagram

4.3.4.5 Communication cables connection-single HHS battery stack



4.3.4.6 Communication cables connection-HHS battery stacks in parallel



GOODWE INVERTER

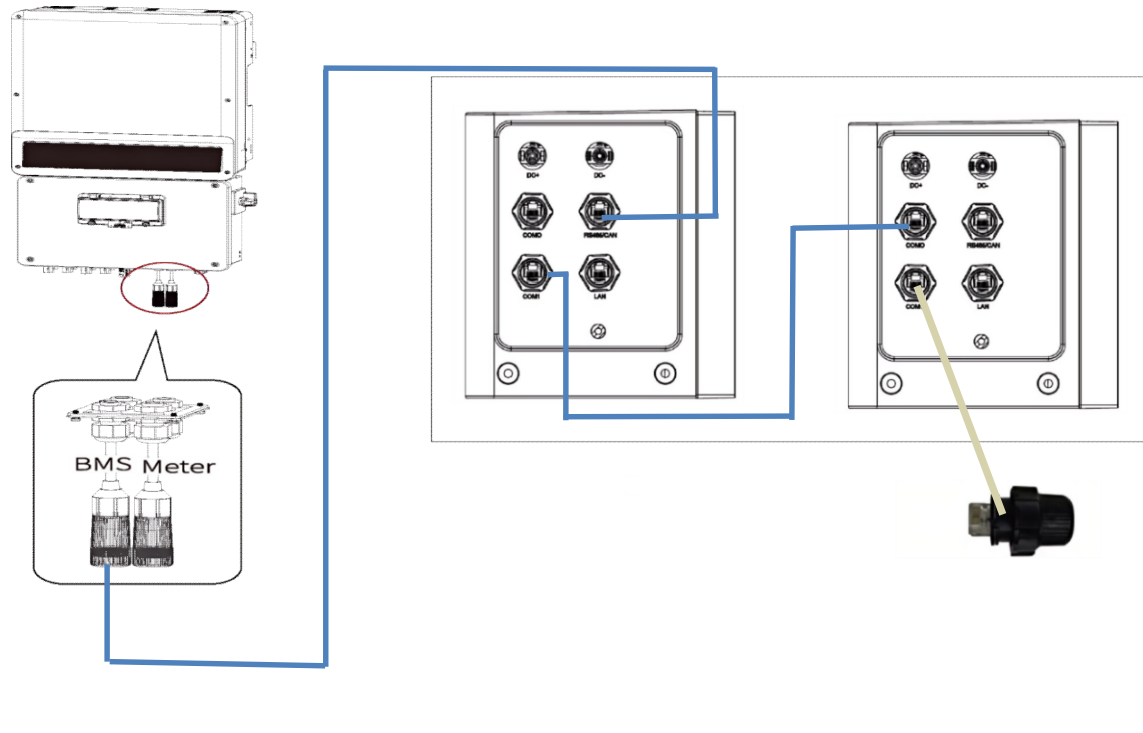

For inverter communication, only the **CAN/RS485** on the master unit needs to be connected. Communication between HHS-1X5K/10K/15K/20K is by connecting **COM0** (slave-side) to **COM1** (master-side) as illustrated above.

5 Power up battery system



Checked all connections thoroughly before powering up.



Read inverter manual together for system power up and power off.

5.1 System power up

- 1) Turn on the PV switch on the left side of the inverter.
- 2) Turn on the circuit breaker for each installed battery stack.
- 3) Turn on the AC circuit breaker between the inverter and the loads.
- 4) Turn on the AC circuit breaker between the backup port of the inverter and the loads (if there is any).
- 5) Turn on the DC isolator of battery stack.
- 6) Press and hold the POWER button of battery stack for 5s.

The POWER button lights up, the output is enabled and the display interface lights up.

Note: Each battery stack system in parallel shall be powered up independently.

5.2 System power off

- 1) Turn off the AC circuit breaker between the inverter and the loads.
- 2) Turn off the PV switch on the left side of the inverter.
- 3) Turn off the circuit breakers of each installed battery stack.
- 4) Turn off the AC circuit breaker between the inverter and the grid (if there is any).
- 5) Press and hold the POWER button of the battery stack for more than 8s.
- 6) Turn the DC isolator of the battery stack to the off position.

The system output is now disabled. Both Power button LED and the display goes off.

Note: Each battery stack system in parallel shall be powered off independently.

5.3 Display description

- The display will automatically turn off after idling for 10 minutes.
Short press the POWER button (1s) to wake up the display.



Table 5-3-1 Display

Item	Description	Function
①	SOC	Digital display of real-time state of charge (SOC)
②		[Constant on] discharging / idling, lit-up blue bar shows SOC. [Flashing] charging (last bar in counterclockwise direction)
③	System status	[Off] normal [Flashing] system fault
④	Heating state	[Constant on] heating function activated, [Off] heating function is not activated
⑤	Network status	[Constant on] Wi-Fi network connection successful [Flashing] Wi-Fi network is not connected
⑥	Battery module status	[constant on] battery module is normal [Flashing] battery module fault

5.4 System configuration

- a. Download and install PowerLite APP

The battery parameter setting and remote monitoring can be realized through the APP software (PowerLite), please go to the App Store or Google Play to search for "PowerLite" to download and install.

- b. Network configuration

- 1) Turn on the Wi-Fi and Bluetooth signal on your phone



- 2) Click Register to go to register an account

(Note: If you have already registered a login account, please ignore this step.)

- ① Enter the registration interface and fill in the information
- ② Receiving the verification by email, enter the verification code
- ③ Tap "register" to complete the registration

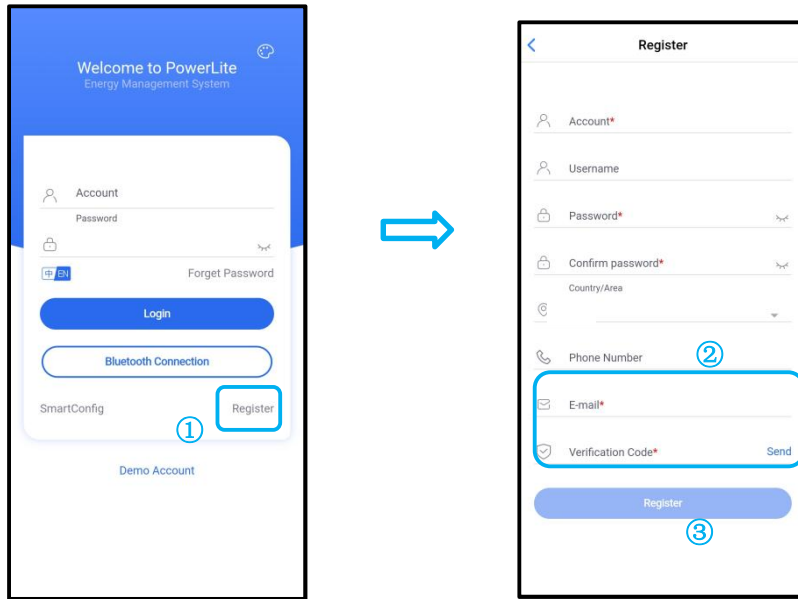

3) Configure the network

(You can check the Bluetooth SN code of battery system at the antenna position of control module)

- ① Click "SmartConfig"
- ② Select the Bluetooth device corresponding to the battery system
- ③ Enter the WiFi network account and WiFi password
- ④ Click "SmartConfig" to complete the networking, the APP displays the successful network configuration information and the WiFi icon on the display is always on, that is, the network configuration is completed.

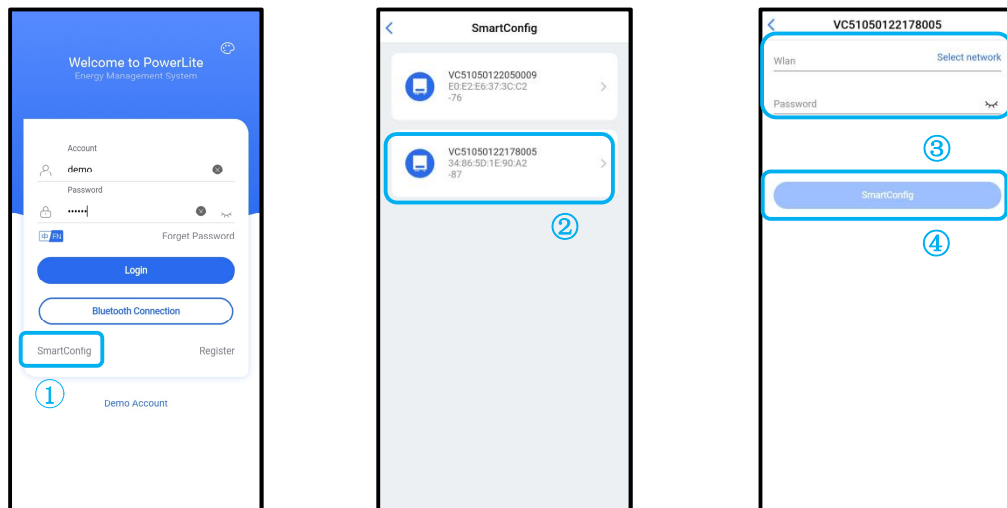

c. Add site/device

(Please check the battery equipment SN on the control module)

Enter the account, password and verification code

- ① Click "Log in" to log in
- ② After logging in, click the top right corner icon of the main interface to add a site

- ③ After established the power station, then add equipment
- ④ Enter the SN code on the nameplate of the control module to add, then click "Assigned Plant" to bind the battery equipment to the established power station
- ⑤ Click "Done" to complete the site/device addition

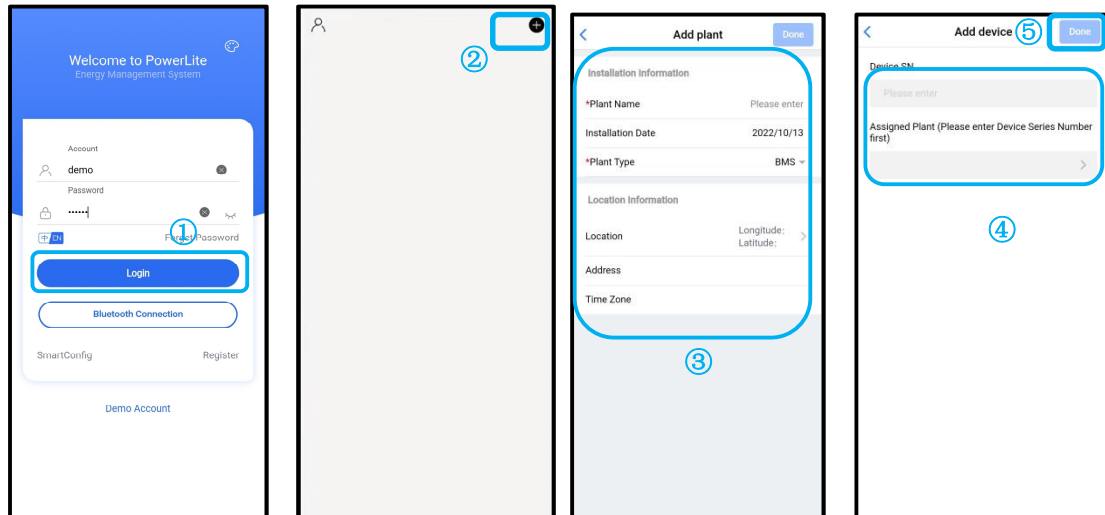

Note: The configuration steps have finished after step c. Because HHS-1X(5/10/15/20)K can automatically adapt to the inverter protocol, it doesn't need to set the inverter manufacturer parameters. Please check the Battery Communication Compatibility List, match the compatible inverter.

6 Maintenance and troubleshooting

6.1 Routine maintenance

- The energy storage system is in daily operation status. It is recommended to check regularly by user, the inspection record as follows. If there is any problem, please contact suppliers in a timely manner.

NO.	Checklist	Maintenance period	Inspection	checker
1	Environment: a. Check whether the debris or animals near the system; b. Check whether the flammables, explosives or corrosive chemicals near the system; c. Check whether the foreign objects on top of the system.	Annual inspection	[√/×]	
2	Appearance: a. Check whether the system nameplate and warning label are clearly display, paste completely without damage; b. Check the system for no corrosive dirt or liquid; c. Check whether the fixed screws and brackets of the system are not loose or deformed; d. Check whether the system is not damaged or deformed, and the battery is not bulging.	Annual inspection	[√/×]	
3	Cable: a. Check whether the ground connection of the system is normal without loose; b. Check whether the power connection and communication connection of system is normal without loose; c. Check that the cables is intact and free of damage.	Annual inspection	[√/×]	
4	Operation: a. Check the normal operation of the system without alarm; b. Check that the system display is normal; c. Check that the app operating device of the system is normal; d. Check the system operation record through the app without abnormalities.	Monthly inspection	[√/×]	

- The energy storage system is in long time no operation status. It is recommended the user do as follows. If there is any problem, please contact suppliers in a timely manner.
 - a. Disconnect the battery if not being used

BMS consumes power even when the battery is not being used. Disconnect the battery output to prevent the battery from becoming empty.

- b. For store-away, make sure the SOC not be less than 30% before disconnect.
- c. Charge the battery system through the inverter every 6 months, and keep the SOC of system isn't below 10%.

- The batteries are in storage without using. It is recommended to maintenance charge the batteries every 6 months

From the date of manufacturer shipment, the battery shall be maintained every 6 months. Action must be taken in case SOC reaches 10%.

Ambient temperature	Must be recharged within
(45, 50] °C	7 days
(35, 45] °C	15 days
≤35°C	30 days

6.2 Fault checklist

Fault	Cause	Solution
No voltage output when power on, without the POWER button light on	<ol style="list-style-type: none"> 1. Press the POWER button for less than 3s 2. Battery module failure 	<ol style="list-style-type: none"> 1. Please try to restart the system. Press the POWER button for 5s. 2. Please contact the supplier for repair or replace the battery module.
No voltage output when power on, with the POWER button light on	<ol style="list-style-type: none"> 1. The battery cannot be started due to external failure 2. Battery module failure 3. Control module fuse blown 	<ol style="list-style-type: none"> 1. Check the external wiring circuit, or disconnect the external wiring and try to restart again. 2. If it cannot be started after the external wiring is disconnected, check or replace the battery pack. 3. Check the connection of fuse in the control module. If not, please contact the professional engineer of manufacturer to deal with the problem.
Inverter won't start	<ol style="list-style-type: none"> 1. The battery voltage is too low or the SOC is lower than the shutdown protection value 2. Battery module failure 	<ol style="list-style-type: none"> 1. Charge the battery after starting the inverter from the grid or PV. 2. Check the external wiring circuit, or disconnect the external wiring and try to power on again. 3. Please contact the supplier for more information.
Inverter CAN communication fails	<ol style="list-style-type: none"> 1. Inverter manufacturer's parameter setting without setting in PowerLite APP; 2. Inverter/battery type selection error 3. Terminal resistor is not installed on COM1 port of control module 	<ol style="list-style-type: none"> 1. Log in to the PowerLite APP to reset PCS setting. 2. Select the corresponding battery type on the inverter. 3. COM1 install terminal resistor 4. Check the consistency of communication pin definitions between inverter and battery.

	4. Inverter communication line pin connection error.	5. Please contact the supplier for more information.
Battery shutdown during charging and discharging	1. The battery is protected because of the excessive input/output power. 2. Battery module failure.	1. Reduce the input/output power of the battery system. 2. Please try to restart the battery system. 3. Log in to the PowerLite APP to view the fault information and contact the supplier
Battery module overcurrent protection	The battery is protected because of the excessive charging/discharging power.	1. Reduce the charging or discharging power of the inverter. 2. Overcurrent fault can be recovered automatically. If the fault is triggered three times in succession, it will be locked and the system needs to be restarted 3. Log in to the PowerLite APP to view the fault information and contact the supplier
Battery module charging and discharging over-temperature protection	1. The installation environment is too hot. 2. The product has been running at rated power for too long. 3. The internal fan of the battery module works abnormally.	1. Check the ambient temperature and the ventilation of battery system. If the ventilation is not well or the ambient temperature is too high, please improve the ventilation and heat dissipation 2. Reduce the load power of the inverter 3. Please contact the supplier for more information to replace the fan
Battery module charging low temperature protection	1. The product installation environment is too cold. 2. The heating film of the battery module works abnormally.	1. Check the ambient temperature of battery system. If the ambient temperature is too low, please improve the environment 2. Please contact the supplier for more information
Automatic shutdown at low battery voltage	The battery is over-discharged and not recharged in time	1. The inverter is set with charging mode, which can charge the battery through the grid or PV 2. Restart the battery and charge it through the inverter 3. Please contact the supplier for more information
Battery module failure	Internal failure of battery module	Log in to the PowerLite APP to view the fault information and contact the supplier
Short discharge time	battery SOC is low	Keep the product charged continuously and keep the energy storage battery system fully charged
	low ambient temperature	Guarantee the product to work within the recommended suitable temperature range
	Product overload	Check load status and remove non-essential loads
	Batteries age and capacity decreases	To replace the battery, please contact the supplier for the battery and its components
Unable to charge and discharge	Internal failure	Log in to the PowerLite APP to view the fault information and

		contact the supplier
	Battery report charging or discharging protection failure	Log in to the PowerLite APP to view the fault information and contact the supplier
	After the battery is discharged to the SOC protection value, it needs to be charged for a period of time before it is allowed to discharge.	The battery is charged to the SOC value set by the restart
	Battery over temperature	Stand at room temperature for more than 3 hours
After the system is powered on, the display cannot be lit or the displayed content is abnormal	1.Display failure 2.Control module fault	1.Please try to restart the battery system. 2.Log in to the PowerLite APP to view the fault information and contact the supplier 3.Please contact the supplier to repair or replace the control module
The display cannot wake up or light up during system operation	1. If the POWER button light is off, the POWER button is faulty or the button wiring is loose 2. The display still does not light up after restart, the display is faulty	1. Log in to the PowerLite APP to view the fault information 2. Please try restarting the battery 3.Please contact the supplier to repair or replace the control module
The number of battery icons displayed on the display screen is inconsistent with the actual number	Communication disconnection	1. Check whether the battery stack is installed reliably, and confirm the abnormal battery through the battery status indicator on the display 2. Please try restarting the battery 3.Please contact the supplier to repair or replace the battery module
The system status light on the display is abnormal and blinks every 1S	Battery module failure	Log in to the PowerLite APP to view the fault information and contact the supplier
The heater works abnormally, and the heating status indicator on the display flashes every 1S	Heating circuit failure	Log in to the PowerLite APP to view the fault information and contact the supplier
Abnormal Bluetooth connection	1Bluetooth account connect error 2. Bluetooth connected to other devices	1. Check whether the paired Bluetooth is consistent with the installed product 2. Disconnect Bluetooth from other devices
Abnormal WiFi connection	1. The Wi-Fi connection is misconfigured 2. The Wi-Fi module is abnormal and the wiring connection is abnormal	1. Check if the battery Wi-Fi connection configuration is correct 2. Check whether the antenna is installed or connected reliably

6.3 Addition of new battery module or replacement guidelines

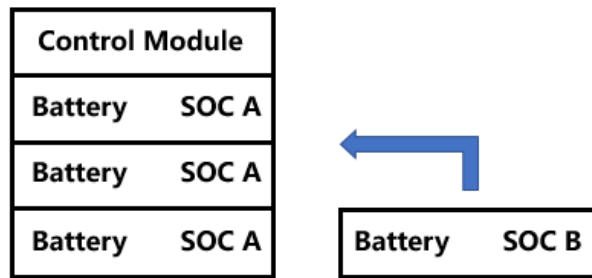

- When a new battery module is added to an existing battery stack, or a faulty battery module is replaced, once installation is completed, please charge the battery stack to SOC 100% before use.

7 Warehouse storage guidelines

7.1 Packaging guidelines

Lithium-ion batteries is recognized as dangerous goods. The packaging requirements for battery products are as follows:

- a. The packaging manufacturer with the packaging qualification for dangerous goods is responsible for providing product packaging, and the packaging manufacturer has a record in the local Commodity Inspection Bureau;
- b. After the packaging manufacturer completes the packaging, the supplier needs to apply to the Commodity Inspection Bureau, and the Commodity Inspection Bureau will provide the "Dangerous Package Product Use Inspection Sheet" and "Dangerous package product performance inspection sheet", and complete the dangerous package commodity inspection;
- c. All battery packs should be packaged with product instruction manuals. The packaged product should be placed in a dry, dust-proof and moisture-proof packing box;
- d. The product name, model, quantity, gross weight, manufacturer, and ex-factory date should be marked on the outside of the packing box.
- e. The necessary signs such as "upward" and "fear of fire" shall meet the requirements of GB/T 191;
- f. The packing method is: packing in a carton with molded foam buffer material in the carton;
- g. Accessories packaging: single accessories are first fastened with cardboard or plastic film or braided straps, neatly placed in the carton, and filled with regular fillers (foam pads, cardboard, etc.) to prevent the accessories from shifting in the box. The following documents should be included with the product when leaving the factory:
 - 1) Product certificate;
 - 2) Product use user manual;
 - 3) Product packing list;
 - 4) Factory inspection report.
- h. Clean battery

Regular cleaning of the battery system is recommended. If the case is dirty, use a soft dry brush or dust collector to remove the dust. Corrosive liquids should not be used to clean the housing. Cleaning liquid materials include solvents, abrasives, etc.

i. Packaging step

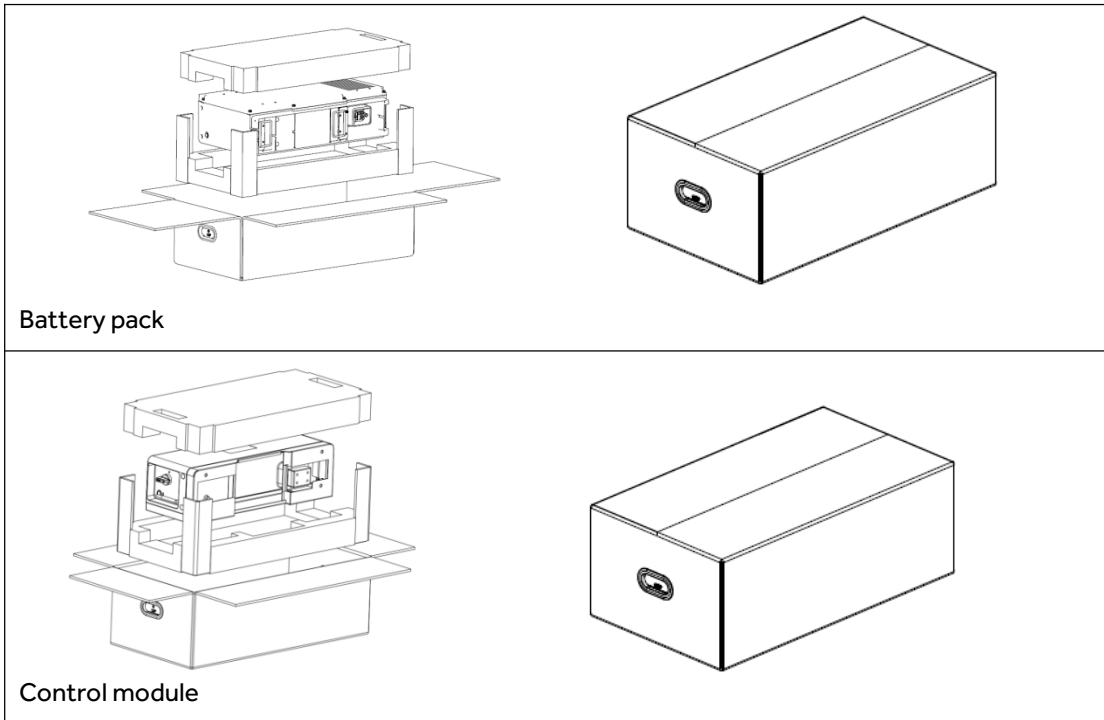

7.2 Storage

The battery pack is stored in a clean, dry and ventilated room with an ambient temperature of $25^{\circ}\text{C}\pm 5^{\circ}\text{C}$ and a relative humidity of not more than 75%. The battery pack has a state of charge of 45% to 55%. Avoid contact with corrosive substances and keep away from fire and heat sources.

8 Dispose of used batteries

Comply with applicable local regulations for the disposal of electronic waste and used batteries.

- Do not mix with your household waste.
- Do not expose the battery to high temperatures or direct sunlight.
- Do not expose batteries to high humidity or corrosive environments.
- Do not crush or pierce batteries

Contact supplier or original manufacturer for disposal options.

9 Detailed specifications

Item	Parameter			
Battery Control module	H0K6050P03-H			
Operating voltage	250~550Vdc			
Max. current	50A			
Battery module model	B40012DP03-H			
Cell Type	LFP			
Rated Voltage	400V, with DC-DC power module built-in			
Rated energy	5kWh			
Group method	16S1P			
Battery System model	HHS-1X5K	HHS-1X10K	HHS-1X15K	HHS-1X20K
No. of battery module	1	2	3	4
Rated energy	5kWh	10kWh	15kWh	20kWh
Rated power	2.5kW	5kW	7.5kW	10kW
Max. charge current	6A	12A	18A	24A
Max. discharge current	6.5A	13A	19.5A	26A
Dimensions W*H*D, mm	653*553*189	653*868*189	653*1183*189	653*1498*189
Net weight	65kg	117kg	169kg	221kg
Rated voltage	400V			
Operating voltage	350V~440V			
External communication	CAN/RS485/WiFi /Bluetooth			
WiFi Frequency range	2412-2472MHz			
WiFi Max. Transmission power range	< 20dBi			
Bluetooth Frequency range	2402-2480MHz			
Bluetooth Max. Transmission power range	< 8dBi			
Warranty	10 years (details in warranty agreement)			

Cycle life	6000 times (25°C, 0.5C/0.5C, 90%DOD)
Scalable	Up to 2 cabinets in parallel
Protection class	IP65
Operating temperature	Charging [-10,50] °C; Discharging [-20,50] °C
Working humidity/ altitude	10%~95%RH/<4000m
Certification	IEC62619,CE,UN38.3,VDE2510-50,UL1973,CEC

Qingdao Nahui Energy Technology Co., Ltd.
Room303, Entrance 1, No.4 Building, Lan Gu Entrepreneurship Center Phase 1, No. 7, Keji
Yilu Road, Aoshanwei Sub district Office, Jimo District, Qingdao, Shandong
www.nahui-newenergy.com