

# Haier

## Heat Pump Water Heaters Monoblock + Split System

Significantly more efficient than traditional electric water heaters.







## Our Brand

Empowering smarter, happier, and healthier living, Haier leads with smart technologies across a range of home appliances. As the top global major appliances brand for over a decade, Haier's products are designed to enable better living through innovation\*.

39

Year History

FOUNDED IN CHINA  
IN 1984



Experience

OPERATING IN  
160 COUNTRIES



Quality

10 R&D CENTRES  
GLOBALLY



Service

NATIONWIDE  
SUPPORT

### Heating and cooling expertise

Haier is the world's largest manufacturer of electric hot water systems. We have been making hot water products since 1986 and during that time have sold over 200 million systems around the globe. Haier has been manufacturing efficient electric heat pump systems since 2010 and have sold over 5 million units during this time.

Founded in China in 1984, Haier has consistently prioritised understanding its customers' unique needs. This customer-centric approach has fueled the development of smart home appliances that blend technological innovation with functionality. Haier's unwavering focus on smart ecosystems has propelled it to the forefront of the industry, making it the world's leading brand of connected air conditioners in 2022 with an impressive market share of over 33% in volume sales\*\*.

In Australasia, Haier's strength is complemented by Fisher & Paykel, a trusted brand that is now part of the Haier Group. Together, they leverage Haier's global reach and Fisher & Paykel's local service network to provide industry-leading products and support to our customers in Australia and New Zealand.

\* Data source: Euromonitor International Ltd, research conducted in February 2023 based on 2022 retail volume sales data. Major Appliances category is the sum of dishwashers, home laundry appliances, large cooking appliances, microwaves and refrigeration appliances. Volume sales refers to sales in retail channel, builder merchants and construction channel.

\*\* Data source: Euromonitor International Ltd, research conducted in February 2023 based on 2022 retail volume sales data. Connected air conditioner is defined as air conditioners with connectivity capability to communicate with other appliances and/or other devices and/or consumers.



## An energy-efficient way to heat your water

Heat Pump Water Heaters bring new innovation to hot water heating – using less energy than standard electric water heaters.\*

Monoblock



Split System



### Efficient design

Haier heat pump technology results in a 64% to 79% reduction in the amount of electricity used to heat the same volume of water, compared to a traditional electric resistance water heater\*. Heat is drawn in from the surrounding ambient air, with electricity only used for the compressor and the fan, rather than using it to heat the water directly through an electrical element.

### Respect for the planet

Haier heat pump hot water systems have lower electricity use,\* and use low impact refrigerants. They also complement solar PV set-ups, prioritising solar energy to reduce electricity use.\*\*

### Connected home

We believe in integrating smart technology into the heart of every home. The SmartHQ™ app puts control in your hands, allowing you to adjust heating as your hot water needs change – any do it from anywhere.

Change between five user modes using SmartHQ™ on your smartphone: Auto mode, Eco mode with Solar PV mode, Electric mode, Vacation mode and Boost.

\*Energy savings of 64-79% are based on the Haier heat pump water heater range, when compared to a standard resistive electric storage water heater in Zones 1 to 5 in AS/NZS4234.  
\*\*Compared to electric resistance and gas models.





# Monoblock

200L, 250L

## Respect for the planet

Highly efficient compared to electric resistance or gas water heaters, complements solar PV systems, runs only on electricity, and uses the natural refrigerant R290.

GLOBAL WARMING POTENTIAL (GWP)

R-134A  
GWP: 1430

R290  
GWP: 3

CO2  
GWP: 1

## Lower running costs

The heat pump technology results in a 70-79% reduction in electricity used to heat the same volume of water compared to an electric-resistance water heater.\*

## Expansive operating range

Performance in most Australian climates from -7°C to 45°C ambient air temperature.

LOWEST OPERATING RANGE

 -7°C

HIGHEST OPERATING RANGE

 45°C

## Adapts to your life

Use the SmarthQ™ app on your smartphone to easily select from five modes to best suit your needs, allowing you to adjust heating to lower-cost periods, minimise energy use when you're on holidays, or prioritise solar energy to reduce grid-supply if you have solar PV.



\*Energy savings of 70-79% are based on Haier Monoblock 200L and 250L when compared to a standard electric storage water heater in Zones 1 to 5 in AS/NZS4234.



## Respect for the Planet

Haier's Monoblock is a one piece water heater that uses heat pump technology and careful design to create an energy-efficient, high performance water heater.



### Reduced running costs

The heat pump technology results in a 70-79%\* reduction in electricity used to heat the same volume of water compared to an electric-resistance water heater, which is likely to lower your electricity bill, saving you money every year.

### Low GWP refrigerant

Our Heat Pump Water Heater uses R290 which has a GWP of 3. Many heat pumps use R134A. R290 has a global warming potential that is 476 times lower than R134A. As many refrigerants are strong greenhouse gases, the use of refrigerants with low global warming potential (GWP) is seen as a way to minimise the effect of refrigeration systems on global warming.

### Eco mode

Eco mode optimises the benefits of solar PV and lower cost, time-of-use electricity.

The Solar PV mode and time-of-use mode (HC) receive a communication signal from an energy management control system (if you have an existing solar PV system). Alternatively, a timer is used to set heating to the low cost periods of a time-of-use tariff.

### Solar PV ready

Surplus solar energy generated by your solar PV system can be stored in the tank.

In Solar PV mode, the Heat Pump Water Heater receives a signal from the solar PV system, notifying it that generated energy is available to use. It uses the available solar PV energy to heat water at up to 75 degrees, storing it for later use.

\* Energy savings of 70-79% are based on Haier Monoblock 200L and 250L when compared to a standard electric storage water heater in Zones 1 to 5 in AS/NZS4234.



## Efficient Design

Designed to make installation as simple and familiar as possible. The inner tank has been designed to minimise heat loss, protect from corrosion, and is thoroughly tested for durability.



### Easy installation

Requires the same installation procedure as an electric storage water heater. If located in the same position, there's minimal need for additional valves or pipe layout changes, making it easy to swap from an electric resistance water heater.



### Longevity

Using patented technology with a triple layer protection creates a long lasting, acid and alkali corrosion resistant inner tank. The inner tank is tested to over 160,000 cycles to ensure durability over the expected lifetime.



### Quiet operation

With an operating noise level of 43dBA at a distance of 1m, the Haier Heat Pump Water Heater is quiet.

## Connected Home

We believe in integrating smart technology into the heart of every home. The SmartHQ™ app puts control in your hands, allowing you to adjust heating as your hot water needs change – any do it from anywhere.

Change between five user modes using SmartHQ™ on your smartphone: Auto mode, Eco mode with Solar PV mode, Electric mode, Vacation mode and Boost.





# Split System

280L

## Lower running costs

Uses only about  $\frac{1}{3}$  of the electricity of a traditional electric resistance heater to heat the same volume of water.\*

**HAIER SPLIT SYSTEM** 64-68% less energy used than electric resistance water heaters\*

## Fast hot water recovery

Perfect for large families and homes in colder regions thanks to quick water reheating, with an impressive 4.58kW heating capacity and a boost function for even faster hot water recovery on the occasional high water use days.

## Low impact refrigerant

This heat pump water heater uses low-impact R32 refrigerant, and is able to complement solar PV systems for lower grid-electricity use.

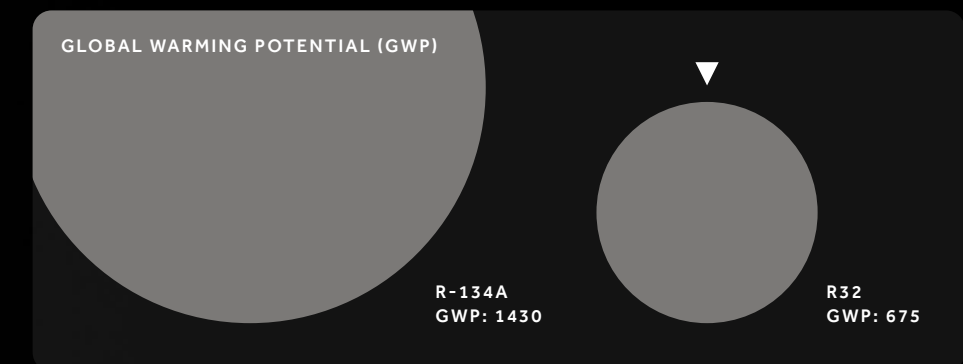

## Installation flexibility

With the heat pump unit split from the cylinder, you have the flexibility to place the heat pump unit outside away from noise sensitive areas and the cylinder outside or inside nearby, in a discrete area.

## Adapts to your life

The built in Wi-Fi module and SmartHQ™ app allows control of your heat pump water heater from anywhere. Change between five user modes, allowing you to adjust heating to lower cost periods, minimise energy use when you're away, or to prioritise solar energy on a sunny day if you have solar PV.



\*Energy savings of 64-68% are based on Haier Split System 280L when compared to a standard resistive electric storage water heater in Zones 1 to 5 in AS/NZS4234.



## Efficient Design

The Haier Split System heat pump water heater has been designed to give you hot water reheating efficiency, as well as the flexibility to install the system indoors, outdoors or split between the two.



### Fast reheating

Water reheats fast with a heating capacity of 4.58kW, the largest in our heat pump water heater range, meaning that even if a large volume of water has been consumed, fresh water is rapidly heated to keep the hot water flowing.

### Heat boost

A back up booster of 2.6kW and built in "one-time boost" further help with fast recovery when hot water use has been particularly high.

### Quiet operation

With an operating noise level of 52dBA at a distance of one metre, the Split System Heat Pump Water Heater is quiet. The outdoor unit can be located away from noise sensitive areas of the home, helping with a good night's sleep even while your heat pump works hard.

### Designed for efficiency

No more electric heating element to heat water – instead this system uses efficient heat pump technology. This technology, which transfers heat from the air to the water in the tank instead of heating via electricity alone, uses 64 to 68% less electricity to heat the same volume of water compared to a traditional electric resistance water heater.\*

### Longevity

Using patented technology with a triple layer protection creates a long lasting, corrosion-resistant inner tank. The inner tank is tested to over 160,000 cycles to ensure durability over the expected lifetime.

\*Energy savings of 64-68% are based on Haier Split System 280L when compared to a standard electric storage water heater in Zones 1 to 5 in AS/NZS4234.



## Respect for the Planet

The Haier Split System uses considered technologies and materials to help reduce our impact on the planet, including the ability to integrate with your solar PV system.

### Reduced running costs

The heat pump technology results in a 64 to 68% reduction in electricity\* used to heat the same volume of water compared to an electric resistance heater, which is likely to lower your electricity bill and save you money every year.

### Eco mode for lower electricity use

Eco mode optimises the benefits of solar PV and lower cost, time-of-use electricity when you have a separate solar PV system. With Solar PV mode, your heat pump water heater integrates with your solar PV system to maximise consumption of PV solar-generated energy, which can help to reduce your power bill.

### Low GWP refrigerant

Our Split Heat Pump Water Heaters use R32 refrigerant, a next generation refrigerant that efficiently carries heat and has a significantly lower environmental impact than its predecessors. The GWP (Global Warming Potential) of R32 is 675, nearly half as much as R134A, which is used by many heat pump water heaters.

### Solar PV ready

If you have a solar PV system, surplus solar energy it generates can be stored in the tank as hot water, reducing the use of grid-supplied energy. In Solar PV mode, the Heat Pump Water Heater receives a signal from the solar PV system, notifying it that generated energy is available to use. It uses the available solar PV energy to heat water at up to 75 degrees, storing it for later use.

## Connected Home

We believe in integrating smart technology into the heart of every home. The SmartHQ™ app puts control in your hands, allowing you to adjust heating as your hot water needs change – any do it from anywhere.

Change between five user modes using SmartHQ™ on your smartphone: Auto mode, Eco mode with Solar PV mode, Electric mode, Vacation mode and Boost.





# Specifications

## Monoblock Heat Pump Water Heater

Model HP200M1-U1



Model HP250M1-U1



## Installation dimensions and clearances\*

	HP200M1-U1	HP250M1-U1
A	630	630
B	267	267
C	979	1272
D	1658	1951
E*	300	300
F*	>100	>100

UNITS IN MM

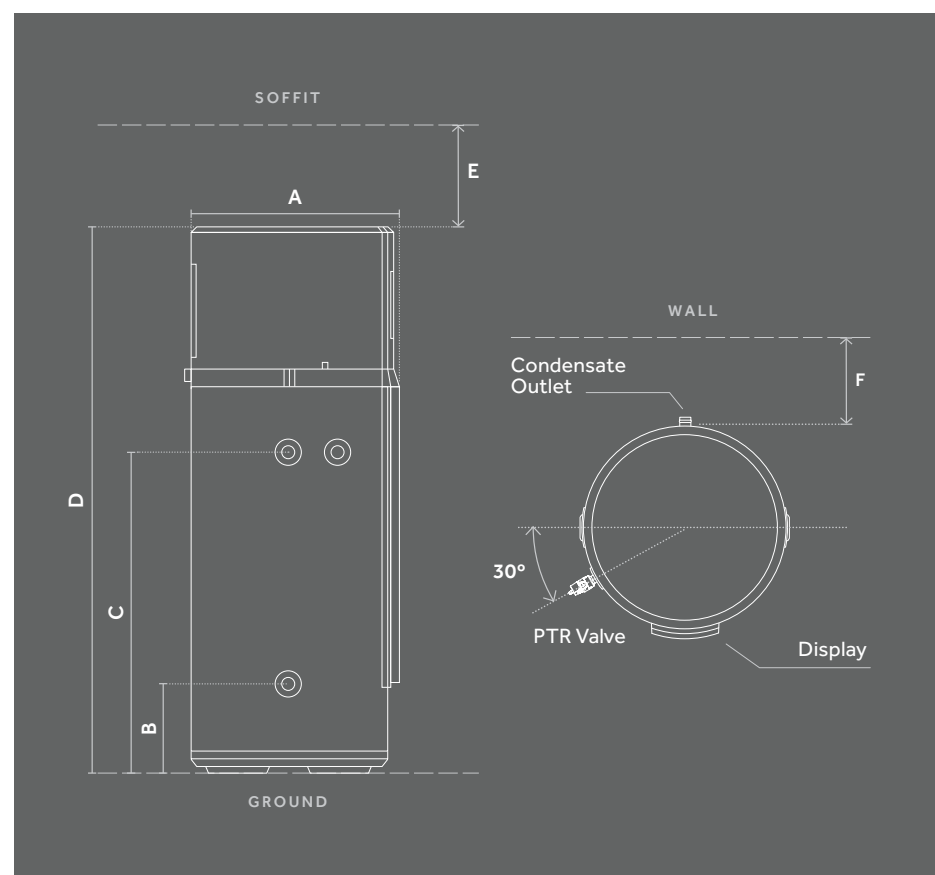

\*Installation Clearances to soffits. Note: This appliance must be installed in a location where it can be quickly and easily drained and moved to a location with 1000mm clearance above the appliance. This is so the anode to be removed for checking and replacing during the 5 yearly service.

Model	HP200M1-U1	HP250M1-U1
<b>Tank</b>		
Total water capacity	195L	246L
Rated voltage/ frequency	220-240V/50Hz	20-240V/50Hz
PTR setting	700kPa	700kPa
Ingress protection	IPX4	IPX4
Hot & cold inlet connections	¾" RP	¾" RP
PTR connection	¾" RP	¾" RP
COP* @ 20°C/15°C	4.49	4.48
Power input of electric element	1.5kW	1.5kW
Rated power input of heat pump	0.43kW	0.43kW
Maximum power input of heat pump	0.75kW	0.75kW
Maximum power input of the appliance	2.25kW	2.25kW
Average heating capacity by heat pump	2.0kW	2.0kW
Default temperature setting	60°C	60°C
Heating range (with element)	35°C – 75°C	35°C – 75°C
Heating range (heat pump only)	35°C – 65°C	35°C – 65°C
Refrigerant type / weight	R290/0.34kg	R290/0.34kg
Noise	43dB(A)	43dB(A)
Ambient temperature range	-7-45°C	-7-45°C

### Dimensions

Product dimensions	600 x 630 x 1658mm	600 x 630 x 1951mm
Product weight (empty)	91kg	106kg

\* Performance (20°C/15°C Ambient air temperature, 15°C -55°C water temperature)  
 \* The COP was measured under test conditions with an ambient air temperature of 20°C/15°C (Dry Bulb/Wet Bulb) and heating of the water from 15°C to 55°C during water heater operation.  
 \* The noise level was measured at 1 m from the water heater during a Noise Test conducted to Standard GB/T 23137 in a hemi-anechoic chamber within a laboratory



# Specifications

## Split System Heat Pump Water Heater

### Model HP300S2-F7

(This kit contains the models: THP300S2-F7 & EHP50 S2-F7)



	EHP50 S2-F7
A	<200
B	<600
C	123
D	>600
E	545
F	780
G	>200

UNITS IN MM

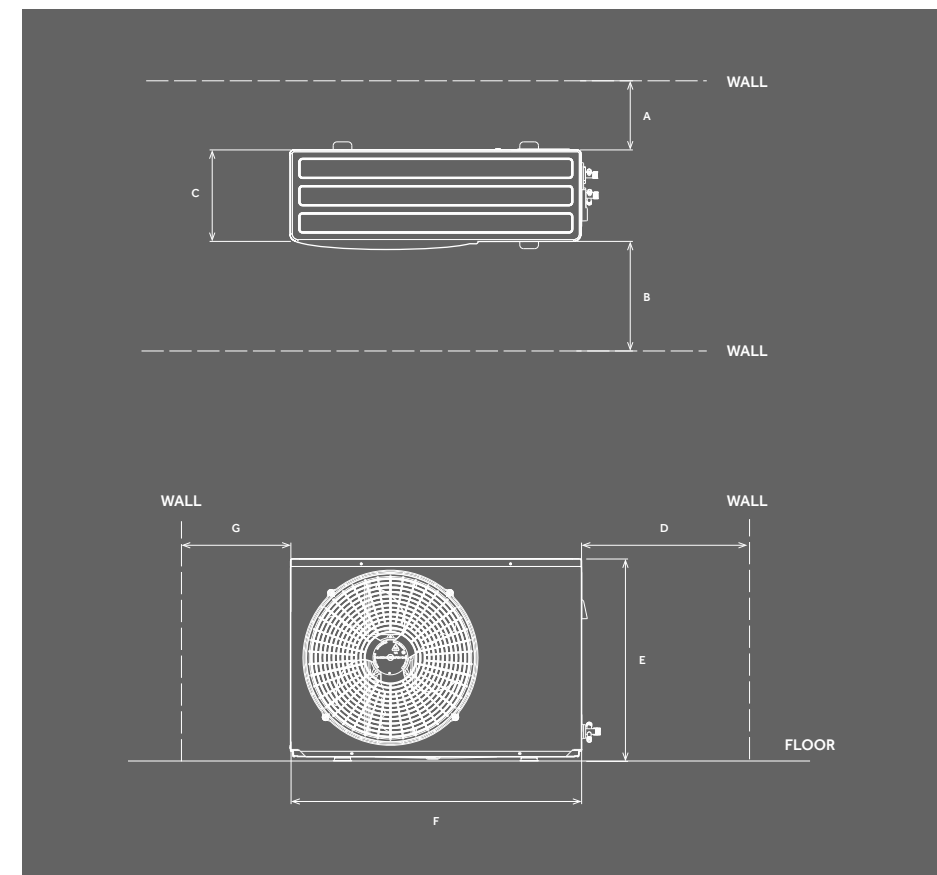

## Installation dimensions and clearances\*

	THP300S2-F7
A	580
B	194
C	299
D	269
E*	1410
F*	1694
G	622

UNITS IN MM

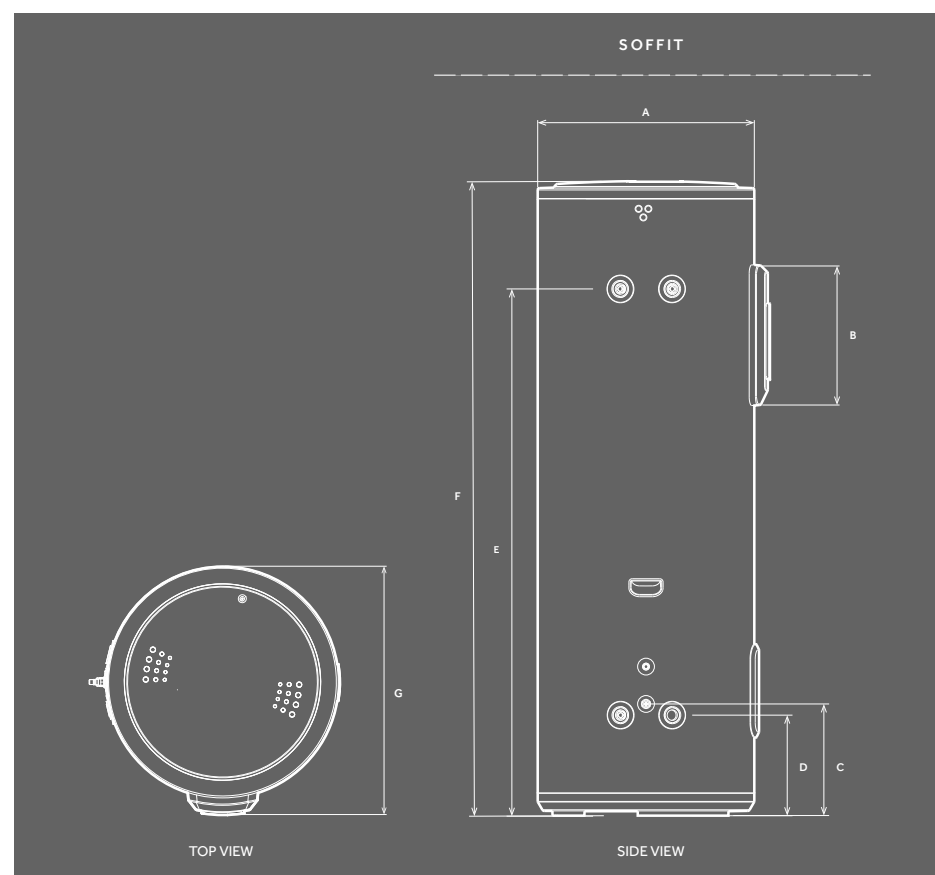

\*Installation Clearances to soffits. Note: This appliance must be installed in a location where it can be quickly and easily drained and moved to a location with 1000mm clearance above the appliance. This is so the anode to be removed for checking and replacing during the 5 yearly service.

Model	HP300S2-F7
<b>Tank</b>	
Total water capacity	276L
Rated voltage/ frequency	220-240V/50 Hz
PTR setting	700kPa
Ingress protection	IPX4
Hot & cold inlet connections	¾" RP
PTR connection	¾" RP
COP* @ 20°C/15°C	4.48
Power input of electric element	2.6kW
Rated power input of appliance	4.3kW
Maximum power input of heat pump	1.19kW
Maximum power input of the heat pump	1.7kW
Average heating capacity by heat pump	4.58kW
Default temperature setting	55°C
Heating range (with element)	35°C - 75°C
Heating range (heat pump only)	35°C - 55°C
Refrigerant type / weight	R32/0.93kg
Maximum refrigerant pipe length	3m
Noise	52dB(A)
Ambient temperature range	-15-45°C
<b>Dimensions</b>	
Product dimensions	580 x 622 x 1694 mm
Product weight (empty)	86kg

\* Performance (20°C/15°C Ambient air temperature, 15°C -55°C water temperature)

\* The COP was measured under test conditions with an ambient air temperature of 20°C/15°C (Dry Bulb/Wet Bulb) and heating of the water from 15°C to 55°C during water heater operation.

\* The noise level was measured at 1 m from the water heater during a Noise Test conducted to Standard GB/T 23137 in a hemi-anechoic chamber within a laboratory



# Warranty and Support

## Warranty

With a warranty of up to 7 years on the inner cylinder, you have peace of mind.

		Inner Cylinder	Other Components
Domestic Use	Parts	7 Years	5 Years
	Labour	5 Years	5 Years
Commercial Use	Parts	1 Year	1 Year
	Labour	1 Year	1 Year

Our goods come with guarantees that cannot be excluded under Australian Consumer Law. You are entitled to a replacement or refund for a major failure and compensation for any other reasonably foreseeable loss or damage. You are also entitled to have the goods repaired or replaced if the goods fail to be of acceptable quality and the failure does not amount to a major failure. Our Manufacturer's Warranty is in addition to any rights and remedies that you may have and is not intended to limit any rights you may have, under Australian Consumer Law or any other law in relation to our products.

## Federal Small-Scale Technology Certificate (STC's)

In addition to the Federal STC rebates, state rebates are also available in some states to replace inefficient water heating technologies with efficient technologies such as hot water heat pumps.

### AUSTRALIAN SMALL-SCALE TECHNOLOGY CERTIFICATES (STCS)

Listed Code	STC Entitlements for 2024					STC Entitlements for 2025				
	Zone 1	Zone 2	Zone 3	Zone 4	Zone 5	Zone 1	Zone 2	Zone 3	Zone 4	Zone 5
HP200M1-U1	18	17	21	23	22	15	15	18	19	19
HP250M1-U1	18	18	22	24	23	16	15	19	21	20
HP300S2-F7	16	16	19	21	21	13	13	16	18	18

## Local Customer Care

With nation-wide Customer Care support and local warehousing of spare parts, if there is an issue with your water heater, we will help you get back up and running as quickly as possible.





## Customer Care

Visit the website for more information:  
[haierhome.com.au](http://haierhome.com.au)

Customer support and service booking:  
1300 729 948



LEARN MORE ABOUT  
OUR PRODUCT HERE

# Haier