

# Installation Manual for Commercial Air Conditioner Outdoor Unit

AV08IMVURA

AV10IMVURA

AV12IMVURA

AV14IMVURA

AV16IMVURA

AV18IMVURA

AV20IMVURA

AV22IMVURA

No. 0150530707

- Please read this manual carefully before using.
- Keep this operation manual for future reference.

Original instructions

# User Manual

## Contents

Safety .....	1
Installation instruction .....	3
Installation procedure .....	13
Electric wiring and the application .....	27
Failure code .....	40
Trial operation and the performance .....	45
Move and scrap the air conditioning .....	46

## Operation condition:

To use the air conditioner normally, please perform as to the right conditions.

This series is cooling and heating heat recovery models. Only when the system is equipped with VP device, indoor units under different VP device can achieve cooling and heating simultaneously. The modes of the indoors which under the same Valve Package (following text called VP) device should be the same. If the indoors connected without VP device, the indoors only can do cooling mode.

Two-generation valve boxes VP\*-\*A and VP\*-\*B can't be mixed used in one system.

To protect compressor, before startup, the unit should be electrified for over 12 hours. If the unit is not used for a long time, please cut off the power to save energy, or the unit will consume the power.

Operating Range of Air Conditioner				
Cooling dry	Indoor	Max.	DB:32°C	WB:23°C
		Min.	DB:18°C	WB:14°C
	Outdoor	Max.	DB:48°C	
		Min.	DB:-5°C	
Heating	Indoor	Max.	DB:27°C	
		Min.	DB:15°C	
	Outdoor	Max.		WB:15.5°C
		Min.		WB:-15°C
Cooling and heating	Indoor	Max.	DB:27°C	
		Min.	DB:18°C	WB:14°C
	Outdoor	Max.		WB:20°C
		Min.		WB:-10°C

## Warning

- If the supply cord is damaged, it must be replaced by the manufacturer, its service agent or similarly qualified persons in order to avoid a hazard.
- This appliance is not intended for use by persons (including children) with reduced physical, sensory or mental capabilities, or lack of experience and knowledge, unless they have been given supervision or instruction concerning use of the appliance by a person responsible for their safety.
- Children should be supervised to ensure that they do not play with the appliance.
- This appliance can be used by children aged from 8 years and above and persons with reduced physical, sensory or mental capabilities or lack of experience and knowledge if they have been given supervision or instruction concerning use of the appliance in a safe way and understand the hazards involved. Children shall not play with the appliance. Cleaning and user maintenance shall not be made by children without supervision.
- The appliances are not intended to be operated by means of an external timer or separate remote-control system.
- Keep the appliance and its cord out of reach of children less than 8 years.
- Means for disconnection having a contact separation in all poles that provide full disconnection under overvoltage category III conditions must be incorporated in the fixed wiring in accordance with the wiring rules.
- The appliance shall be installed in accordance with national wiring regulations.
- Before connected to the supply mains, the supply cord of the units shall be connected to an all-pole full disconnection circuit breaker, which has been approved per IEC 60898. Please refer to "Electric wiring and the application" on page 23 for details.
- The installation of a residual current device (RCD) having a rated residual operating current not exceeding 30 mA is advisable.
- The maximum working pressure is 4.15MPa. This maximum working pressure shall be considered when connecting the outdoor unit to indoor units.
- The refrigerant used in the outdoor unit is R410A. Please refer to "Installation procedure" on page 20-21 of this manual for the refrigerant charging.
- The outdoor unit shall only be connected to indoor units suitable for the same refrigerant.
- The unit is a partial unit air conditioner, complying with partial unit requirements of the International Standard, and must only be connected to other units that have been confirmed as complying to corresponding partial unit requirements of the International Standard.

# Safety

---

- If the air conditioner is transferred to the others, this manual should be transferred together.
- Before installation, please read "Safety precaution" carefully to confirm the correct installation.
- The mentioned precaution includes "**⚠WARNING**" and "**⚠CAUTION**". The precaution caused death or heavy injury for faulty installation will be listed in "**⚠WARNING**". Even the cautions listed in "**⚠CAUTION**" also may cause serious accident. So both of them are related to the safety, and should be executed severely.
- After installation, perform a trial and confirm everything normal, then introduce the operation manual to the user. Besides, put the manual to the user and ask them to preserve it carefully.

## **⚠WARNING**

- The installation or the maintenance should be performed by the authorized agency. Or the non-specialized operation will cause water leakage, electric shock or fire etc accidents.
- The installation should be executed as per the manual, or the faulty installation will cause water leakage, electric shock or fire etc accidents.
- Please install the unit at the space which can bear the weight. Or the unit will drop down to cause the human injury.
- The installation should defend against the typhoon, and the earthquake etc. Abnormal installation will cause the unit fall down.
- Use the correct cable and make reliable earthing. Fix the terminal firmly and the loose connection will cause heating or fire etc accident.
- The wiring should be in shape and can not be raised. Be earthed firmly and can not be clipped by the electric box cover or the other plate. The incorrect installation will cause heating or fire.
- When setting or transferring the unit, there should not be other air into the refrigerant system except for R410A. The gas mixture will cause the abnormal high pressure which will cause break or human injury etc accidents.
- When installation, please use the accessories with the unit or the special parts, or it will cause water leakage, electric shock, fire, refrigerant leakage etc accidents.
- Don't lead the water drainage pipe into the drainage groove with the poisonous gas, such as sulphur. Or the poisonous gas will enter indoor.
- In installation or after installation, please confirm if there is refrigerant leakage, please take measures for ventilation. The refrigerant will cause poisonous gas as meeting fire.
- Don't install the unit at the place where there may be flammable gas leakage. In case the gas leaks and gather around the unit, it will cause fire.
- The drainage pipe should be installed as per the manual to confirm the fluent drainage. Also take measures for heat insulation against dew drop. Incorrect water pipe installation will cause water leakage even and make the things wet.
- For the liquid pipe and the gas pipe, take measures for heat insulation too. If there is no heat insulation, the dew drop will wet the things.

# Safety

## ⚠CAUTION

- Execute earthing for the unit. But the earthing wire can not be connected to the gas pipe, water pipe, lightning rod or the telephone earthing wire. Improper earthing will cause electric shock.
- Don't install the unit at the place where leaks the flammable gas. Or it will cause fire.
- Execute the water drainage pipe according to the manual, improper installation will cause water leakage to wet the family things.
- The outdoor fan can not face to the flower or the other vegetable, or the blowing gas will make the flower dried up.
- Please ensure the maintenance room, if not, it will cause the maintenance person damaged.
- When installing the unit on the roof or the other high place, to prevent the person falling down, please set the fixed ladder and the railing at the passage.
- Use the two-end spanner, and fasten the nut at proper torque. Don't fasten the nut excessively against the flared setion broken. Or it will cause refrigerant leakage and lack of oxygen.
- Take measures for heat insulation to the refrigerant pipe, or there will be water leakage or dew drop to wet the family things.
- After finishing the refrigerant pipe, make leakage test by charging the nitrogen. In case the refrigerant leaks in a small room and exceeds the limited concentration, it will cause lack of oxygen.
- Don't use the other refrigerant except for R410A. The R410A pressure is 1.6 times higher than R22 pressure. The refrigerant R410A tank is marked with pink sign.
- Against charging different refrigerant, we changed the stop valve diameter of the R410A unit. To enhance the compression consistence, we also changed the flared pipe dimension. Prepare the R410A specially tools according to the below table.

	R-410A specified tools	Remarks
1	Gauge manifold	Range: HP > 4.5MPa, LP > 2MPa
2	Charge hose	Pressure: HP: 5.3MPa, LP: 3.5MPa
3	Electronic balance for charging R410A	Can not use the measurable charging tank
4	Torque spanner	
5	Flare tool	
6	Copper pipe gauge for adjusting projecting margin	
7	Vacuum pump adapter	Must be with reverse stop valve
8	Leakage detector	Can not use freon leakage detector, but the He detector

- When charging refrigerant, the refrigerant must be taken out as liquid state from the tank.
- When installing indoor unit, outdoor, power cable and connecting wire, leave them at least 1m away from the TV set or the radio against interference for the image or the noise.
- In the room with fluorescent lamp (reverse phase or rapid start type), the remote signal may be not reach the pre-set distance. The farther that indoor is away from fluorescent lamp, the better.
- The tightening torque of the stop valve refer to the following table

Operating valve size (mm)	Fastening torque (N.m)	Fastening angle (°)	Recommended tool length (mm)
Ø6.35	14~18	45~60	150
Ø9.52	34~42	30~45	200
Ø12.7	49~61	30~45	250
Ø15.88	68~82	15~20	300
Ø19.05	84~98	15~20	300

- When loaded into a refrigerant, be sure to take it out of the tank.
- Installation of indoor, outdoor, power lines and connections must be at least 1m away from the TV or radio to avoid image interference or noise.
- In a room equipped with fluorescent lamps (RP or fast start), the remote control signal transmission distance may not reach a predetermined value. The farther away the indoor machine is, the better it is.



# Installation instruction

In installation, please check specially the below items:

- If the connected units quantity and the total capacity is in the allowable range?
- If the refrigerant pipe length is in the limited range?
- If the pipe size is proper? And if the pipe is installed horizontally?
- If the branch pipe is installed horizontally or vertically?
- If the additional refrigerant is counted correctly and weighed by the standard balance?
- If there is refrigerant leakage?
- If all the indoor power supplies can be on/off simultaneously?
- If the power voltage is in compliance with the data marked on the rating label?
- If the address of indoors and outdoors has been set?

## Before installation

- 1) Before installation, check if the model, power supply, pipe, wires and parts purchased respectively are correct.
- 2) Check if the indoors and outdoors can be combined as the following.



Outdoor		Indoor		Gather pipe	
Capacity (100W)	Combination type	Indoor Qty	Total indoor capacity (kBtu/h)		
224	Single (8HP)	1~15	126~328	-	
280	Single (10HP)	1~17	140~364	-	
335	Single (12HP)	1~20	168~436	-	
400	Single (14HP)	1~24	200~520	-	
450	Single (16HP)	1~27	225~585	-	
504	Single (18HP)	1~30	252~655	-	
560	Single (20HP)	1~33	280~728	-	
615	Single (22HP)	1~36	308~800	-	
680	Combination (335+335)	1~40	340~884	HZG-R20B	
735	Combination (335+400)	1~43	368~956		
800	Combination (400+400)	1~46	393~1021		
850	Combination (400+450)	1~50	425~1105		
900	Combination (450+450)	1~53	450~1170		
954	Combination (450+504)	1~57	480~1248		
1008	Combination (504+504)	1~60	505~1313		
1064	Combination (504+560)	1~64	533~1385		
1120	Combination (560+560)	1~64	565~1469		
1175	Combination (560+615)	1~64	590~1534		
1230	Combination (615+615)	1~64	620~1612		
1300	Combination (400+450+450)	1~64	650~1690		HZG-R30B
1350	Combination (450+450+450)	1~64	680~1768		
1404	Combination (450+450+504)	1~64	702~1825		
1458	Combination (450+504+504)	1~64	729~1895		
1512	Combination (504+504+504)	1~64	757~1968		
1568	Combination (504+504+560)	1~64	785~2041		
1624	Combination (504+560+560)	1~64	812~2111		
1680	Combination (560+560+560)	1~64	840~2184		
1735	Combination (560+560+615)	1~64	868~2256		
1790	Combination (560+615+615)	1~64	900~2340		
1845	Combination (615+615+615)	1~64	928~2412		

# Installation instruction

Outdoor		Indoor		Gather pipe
Capacity (100W)	Combination type	Indoor Qty	Total indoor capacity (kBtu/h)	
1908	Combination (450+450+504+504)	1~64	960~2496	HZG-R40B
1962	Combination (450+504+504+504)	1~64	988~2568	
2016	Combination (504+504+504+504)	1~64	1020~2652	
2072	Combination (504+504+504+560)	1~64	1048~2723	
2128	Combination (504+504+560+560)	1~64	1075~2795	
2184	Combination (504+560+560+560)	1~64	1103~2867	
2240	Combination (560+560+560+560)	1~64	1120~2912	
2295	Combination (560+560+560+615)	1~64	1148~2984	
2350	Combination (560+560+615+615)	1~64	1175~3055	
2405	Combination (560+615+615+615)	1~64	1203~3127	
2460	Combination (615+615+615+615)	1~64	1230~3198	

- Note:
- If all the indoor units operate at the same time in one system, the total indoor units capacity should be less than or equal to the total outdoor units capacity. Otherwise, overloading operations may occur in bad operating condition or some special conditions. If all the indoor units don't operate at the same time in one system, the total indoor units capacity should be no more than 130% of the total outdoor units capacity.
  - If the system operates in high heat load or cold area (Ambient Temperature below  $-10^{\circ}\text{C}$ ), the total indoor units capacity should be less than the total outdoor units capacity.
  - To choose combinations' wires and air switches according to the Max. operating current of the combinations.

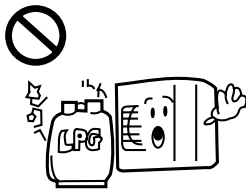
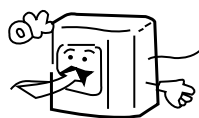
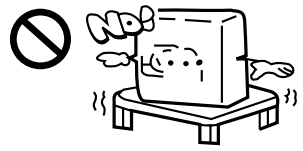
## Installation place selection

<p>Air-conditioner can't be installed in the place with inflammable gas. Or it will cause fire hazard.</p> 	<p>The unit should be installed at the place with good ventilation. No obstacle at the air inlet/outlet. And no strong wind blows the unit.</p>  <p>The installation space refers to the latter info.</p>	<p>The unit should be installed at the strong enough place. Or it will cause vibration and noise.</p> 
<p>The unit should be installed at the place where the cold/hot air or noise will not interfere the neighbours.</p> 	<ul style="list-style-type: none"> <li>The place where the water can flow fluently.</li> <li>The place where no other heat source will affect the unit.</li> <li>Pay attention to the snow against clogging the outdoor.</li> <li>In installation, install the anti-vibration rubber between the unit and the bracket.</li> </ul>	<ul style="list-style-type: none"> <li>The unit is better not be installed at the below places, or it will cause damage.</li> <li>The place where there is corrosive gas (spa area etc).</li> <li>The place blowing salty air (seaside etc).</li> <li>Exsits the strong coal smoke.</li> <li>The place with high humidity.</li> <li>The place where there is device emitting Hertzian waves.</li> <li>The place where voltage changes greatly.</li> </ul>

# Installation instruction

## Transportation

- In transportation, please don't dismantle the packaging, and move the unit to the installation location as closely as possible.
- Don't hang the unit only at two points. When hanging the unit, don't sit on the unit. The unit should be upright. When removing the unit with the forklift, put the fork into the special hole at bottom of the unit. When being hanged, the rope should be 4 pieces of steel cable with over 8mm diameter. Put the cushion at the contact section between steel cable and the unit against the distortion or damage.
- When ring unit use hoisting hole at base of unit. Protect unit against riging damage by using cushion.

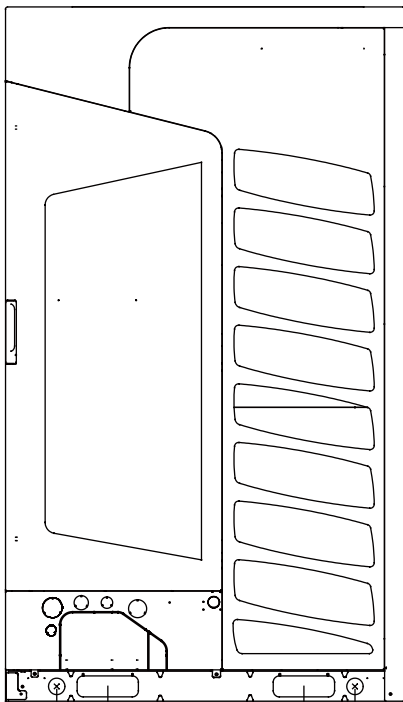
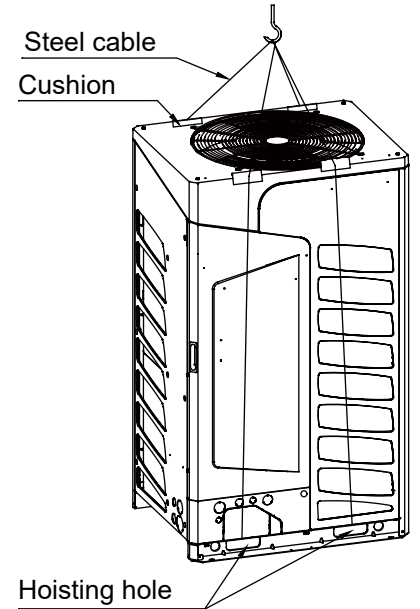

Forklift hole distance 480mm  
Hoisting hole diameter  $\text{Ø}40\text{mm}$ , distance 730mm  
AV08~14IMVURA

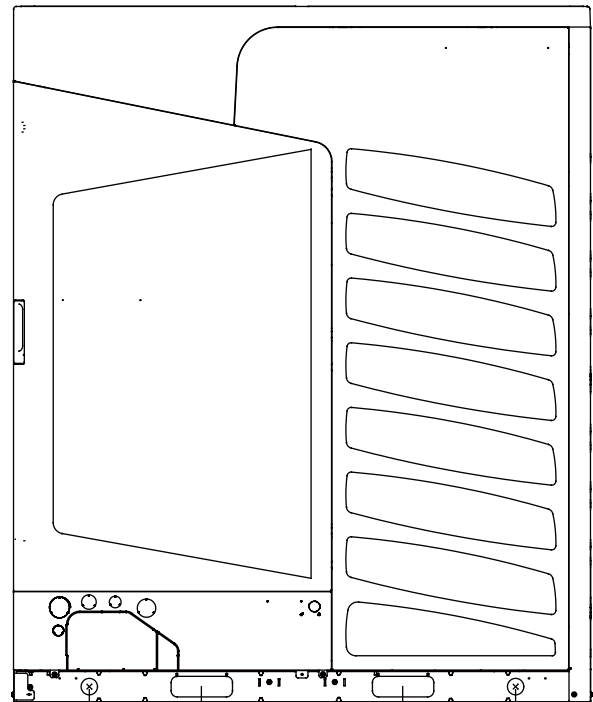

Forklift hole distance 480mm  
Hoisting hole diameter  $\text{Ø}40\text{mm}$ , distance 1042mm  
AV16~22IMVURA

# Installation instruction

## Outline and installation dimensions

**AV08~14IMVURA**

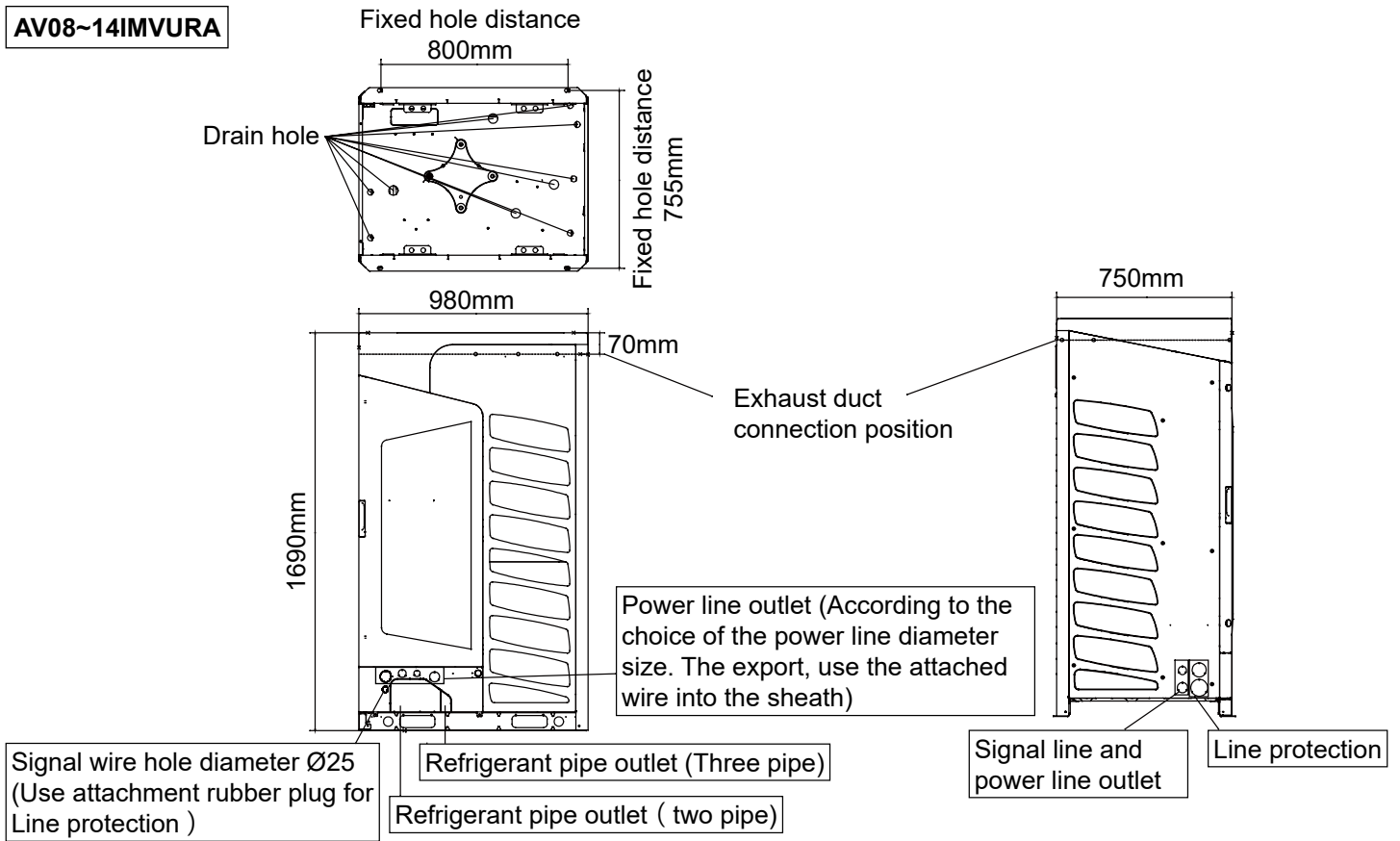

**AV16~22IMVURA**

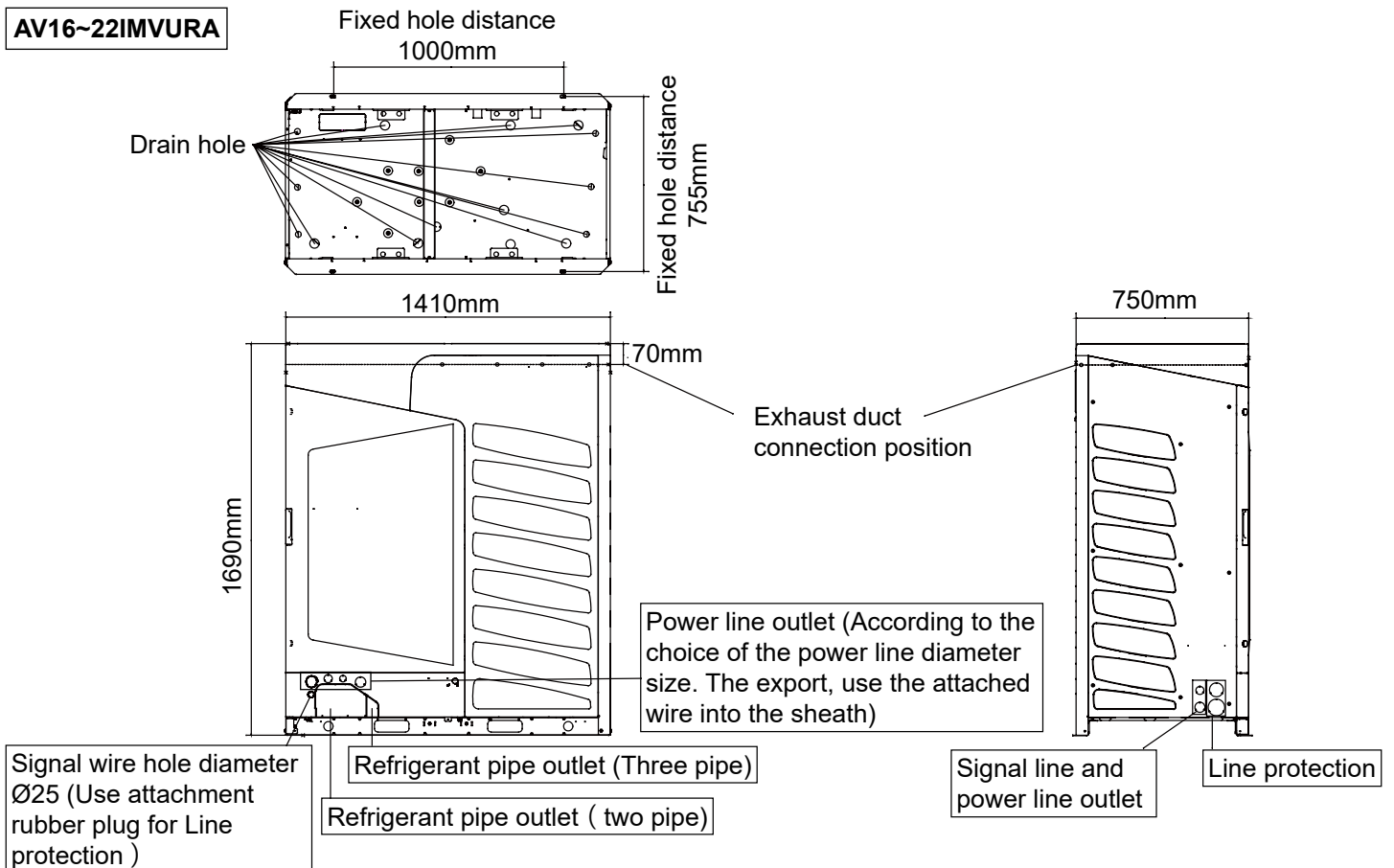

# Installation instruction

## Outdoor unit installation

### Standard accessories

Please check the attachment is complete, please be sure to use.

No.	definition	Graphic	Quantity	Remarks	Place position																
1	Installation instruction		1		Accessory bag																
4	Rubber plug		1	Signal line protection	Accessory bag																
5	sheath		1	Power line protection	Accessory bag																
6	Reducing pipe	<table border="1"> <tr> <td>(8HP)</td> <td>(10HP)</td> <td>(12~14HP)</td> <td>(16~22HP)</td> </tr> <tr> <td> 2</td> <td> 2</td> <td> 2</td> <td> 1</td> </tr> <tr> <td> 2</td> <td> 2</td> <td> 1</td> <td></td> </tr> <tr> <td> 2</td> <td> 1</td> <td></td> <td></td> </tr> </table>	(8HP)	(10HP)	(12~14HP)	(16~22HP)	2	2	2	1	2	2	1		2	1				Reducing pipe	Accessory bag
(8HP)	(10HP)	(12~14HP)	(16~22HP)																		
2	2	2	1																		
2	2	1																			
2	1																				
7	wiring harness		4	Gas liquid pipe insulation binding	Accessory bag																
8	Wrench		1	Remove service panel	The outdoor machine foot beam																

1. Choose a place that can carry the weight of the unit to install and fix, so that the unit will not shake or fall. The unit shall be installed in a flat area (below 1/100).
2. Do not install the unit in the areas where there may be flammable, explosive, corrosive gas leakage.
3. Indoor and outdoor machines should be close to each other as much as possible to reduce the length of the refrigerant pipeline and the number of bends.
4. The installation should be to ensure that units from the sun and rain, dust, typhoon, earthquake proof place. In the area of snow, the machine should be installed in the frame or under the snow cover, so as to avoid the machine snow. See Figure 1
5. Make sure that there is enough room for maintenance
6. Measures should be taken to avoid contact with children
7. The refrigerant pipe by the unit below should be used when the overhead, overhead part height 200mm above. See Figure 2

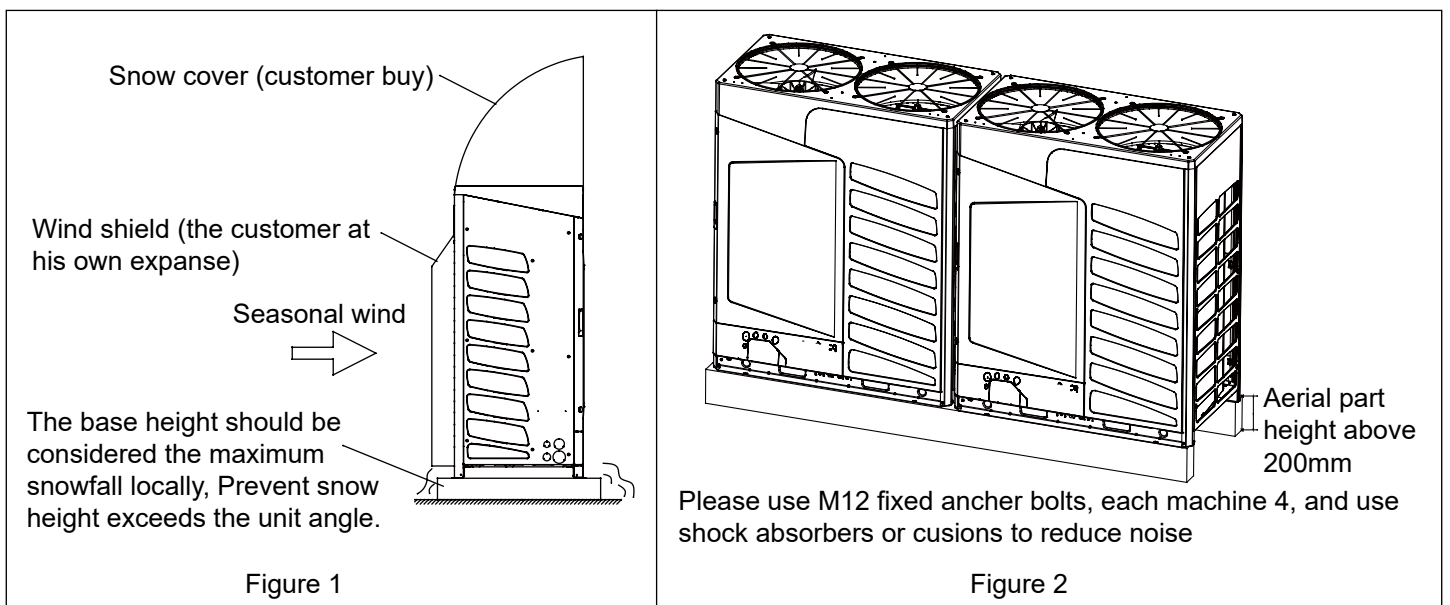

# Installation instruction

## Combination installation dimensions

- There should be no obstacles in 2000mm above the top of outdoor unit;
- Obstacles around outdoor should be greater than 900mm to the bottom of unit.
- When multiple modules are installed, the outdoor should be in ranked as the capacity, the larger capacity is closer to the main pipe of gather pipe.

### 1. Single installation

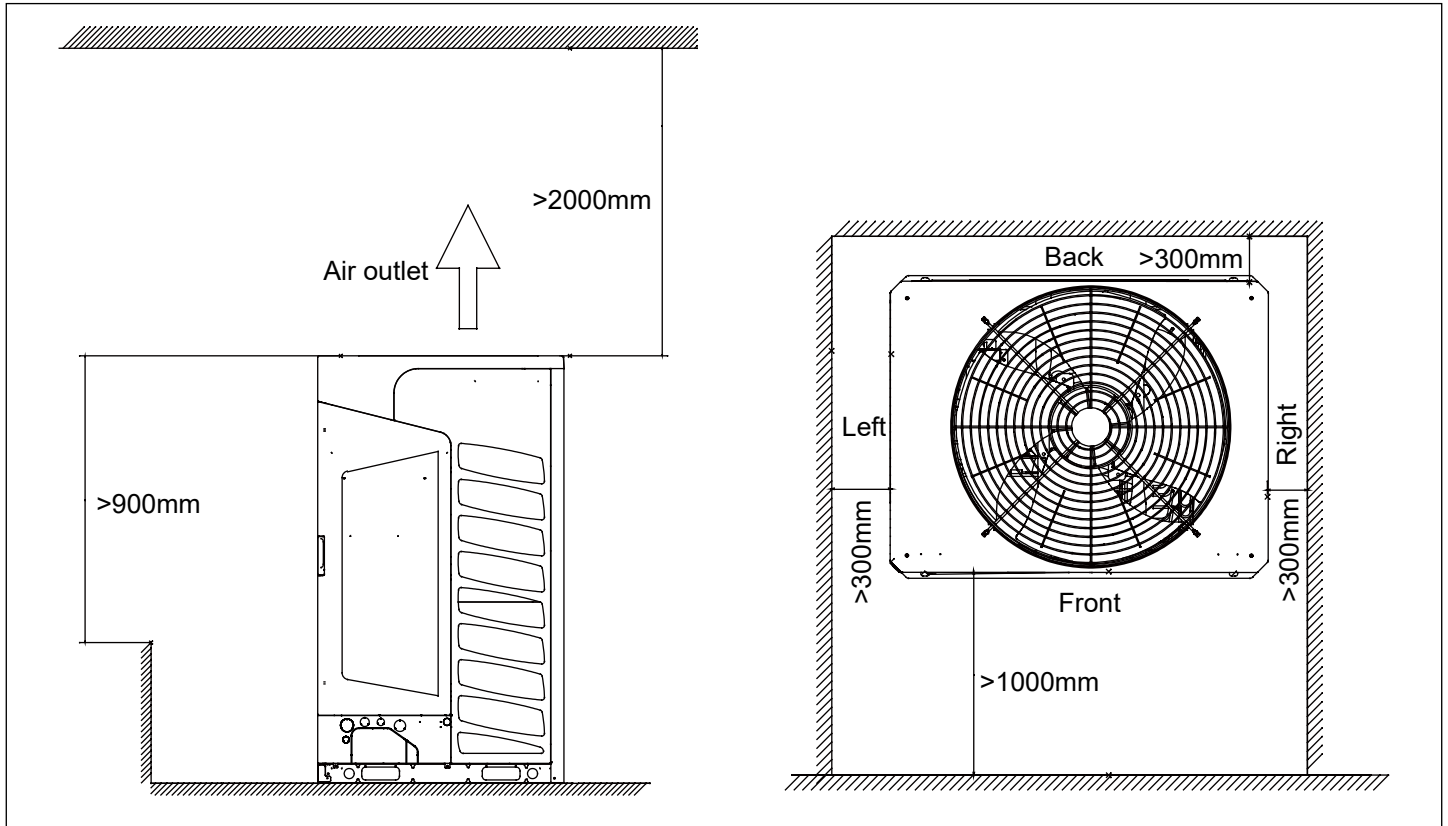

### 2. combination installation

Unit can be installed in the same or opposite direction

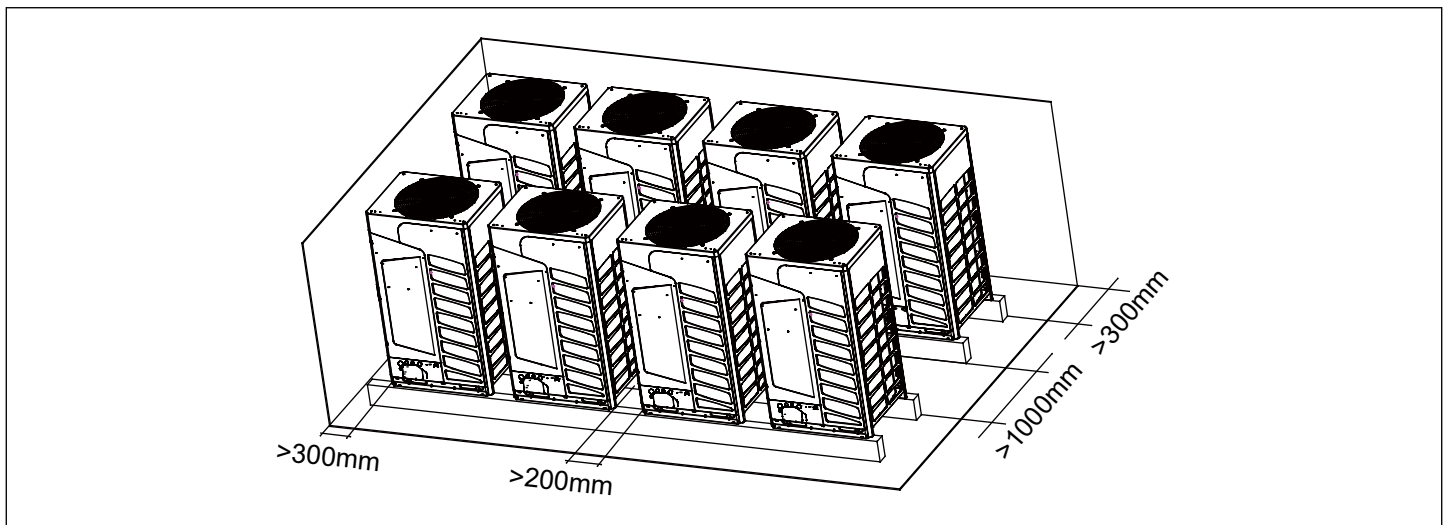

# Installation instruction

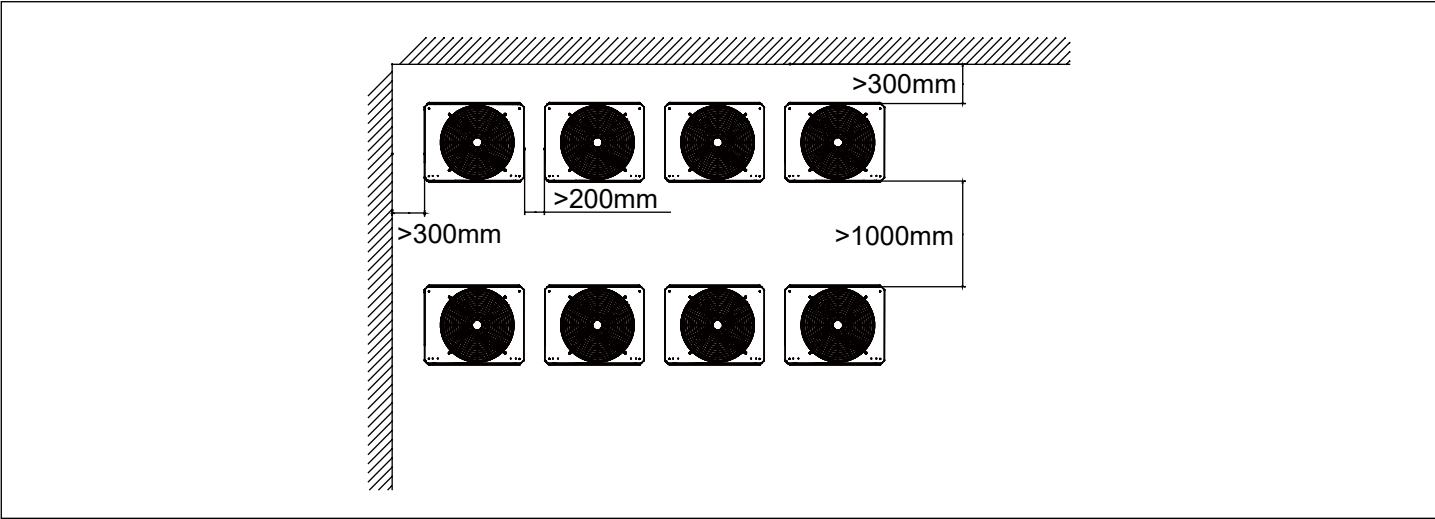

### 3. Wall higher than the outdoor condenser

Place with air inlet hole

Notes:

- a. Fan speed  $V_s$  at air inlet is 1.5m/s or below.
- b. Air outlet height  $H_D = H - h$  and below 1m.

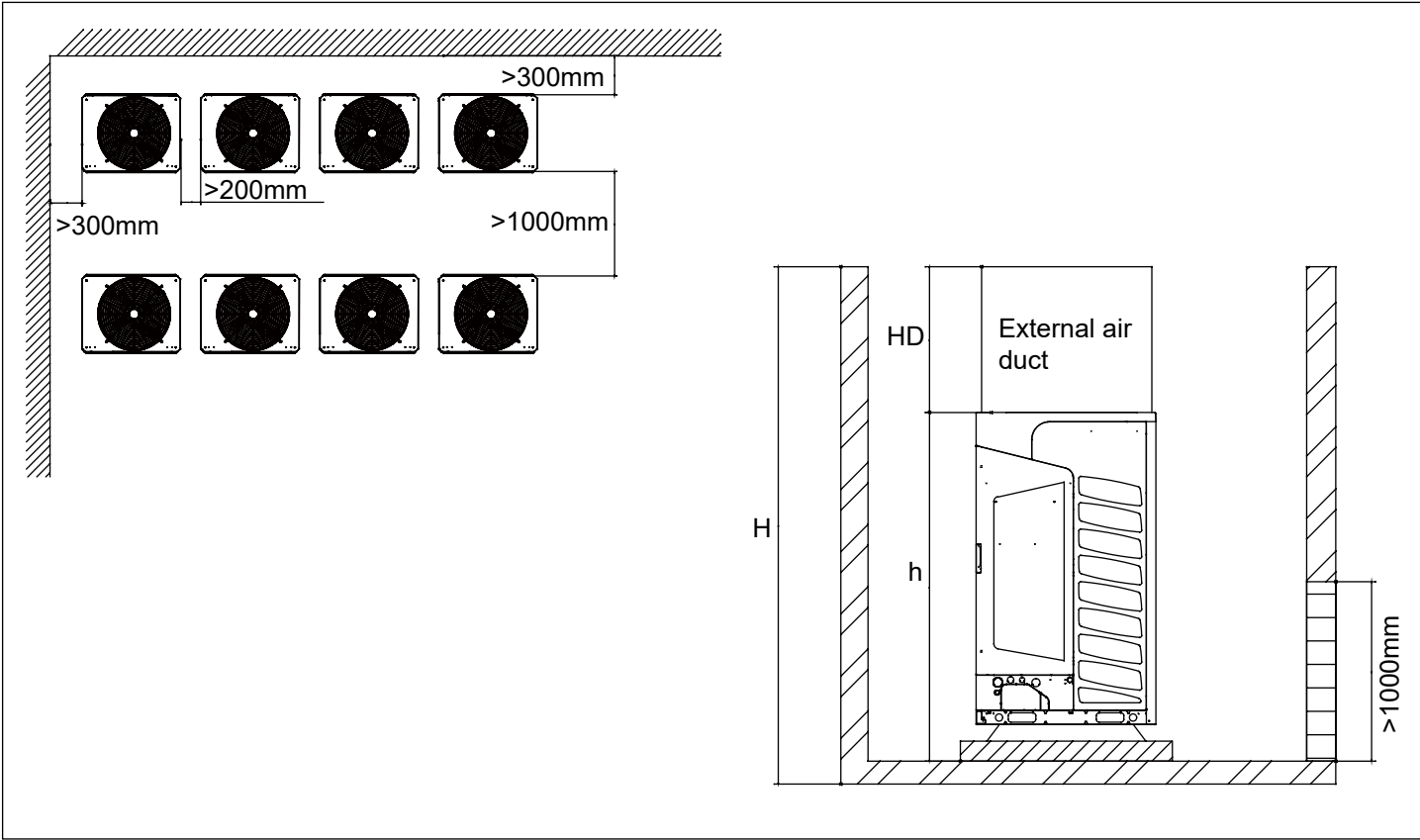

# Installation instruction

Place without air inlet hole

Notes:

- a. Set a 500~1000mm bracket.
- b. Air outlet height  $HD=H-h$  and below 1m.

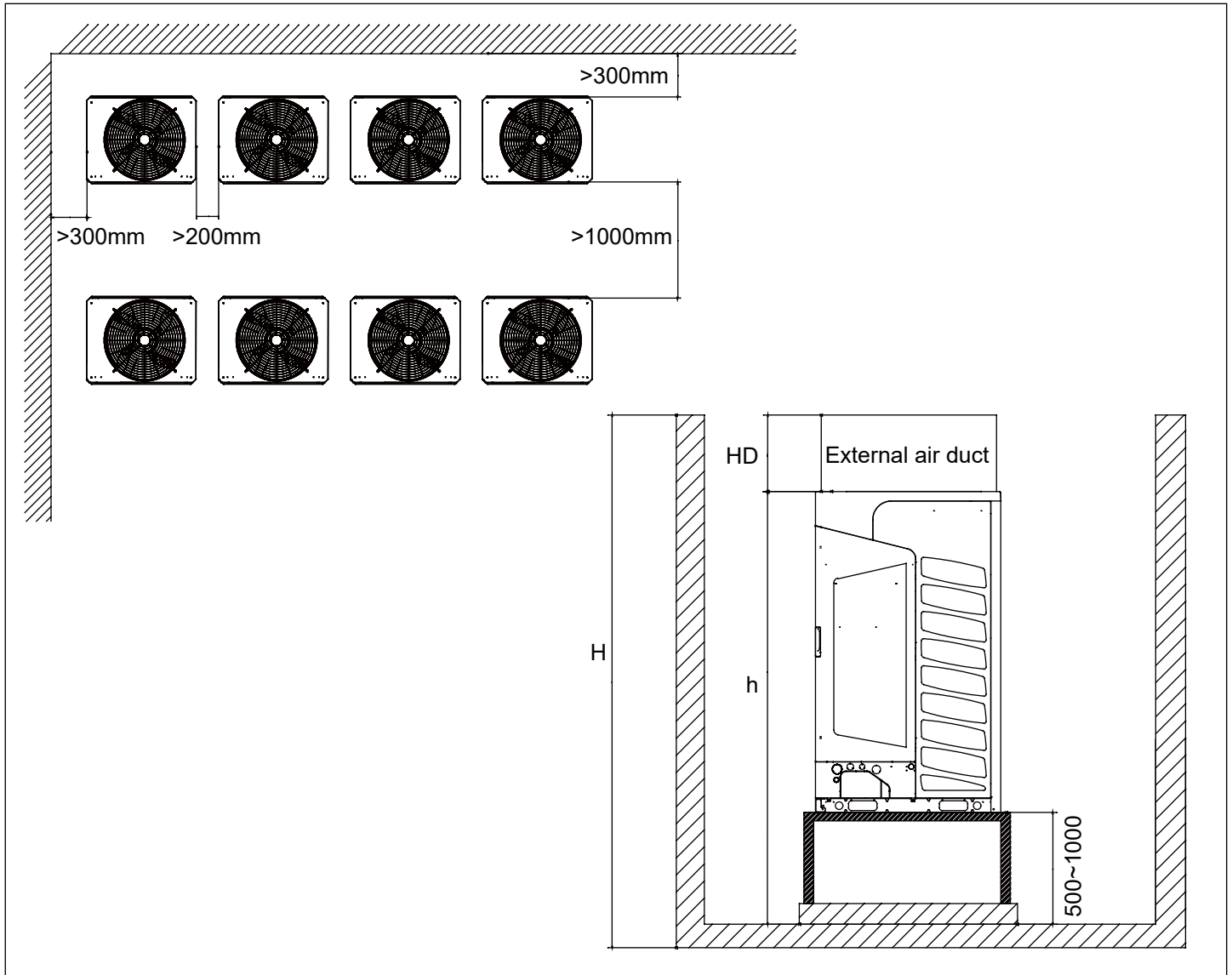

4. The outdoor machine installation should consider the impact of seasonal wind, don't let the wind directly into the unit return air, otherwise it will affect the unit defrosting and related functions

5. Must be arranged to follow the following principles in the exhaust duct

- Install exhaust duct before the machine must be taken out of the wind protection network, otherwise it will affect the output of the unit, and then lead to the decline in performance, and even cause failure
- Increase the blinds, the unit will affect the air out of the air, reduce performance, and therefore do not recommend the use of shutters. To use the shutter angle control at 15 degrees below, the distance between the control of 80mm above
- The exhaust duct is only allowed to have one elbow, otherwise it will cause bad operation of the machine
- Please install the soft connection between the unit and the air duct to prevent vibration and noise
- The exhaust air duct of each machine must be installed independently, and the exhaust hood of the machine is prohibited to be assembled in parallel in any form, otherwise it may cause the failure of the unit.



# Installation instruction

## install snow cover

Snowfall area, please install snow cover, see the right picture. To be unaffected by the snow, it is important to set up a high platform, which is calculated according to the maximum amount of snow in the area. At the same time, the outdoor external machine defrost setting change to be easy to frost setting, detailed see the digital tube setting.

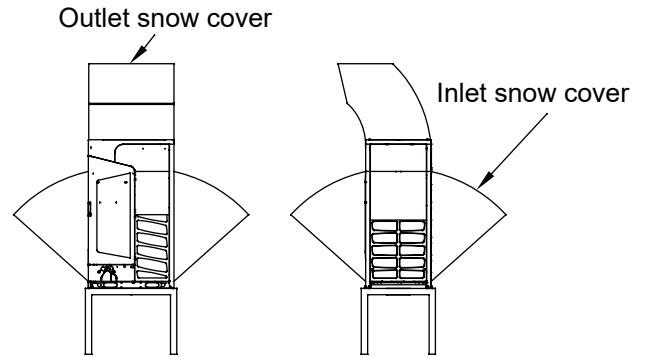

## Panel disassembly instruction

Please refer to the following figure for the repair board to remove.

1. Remove the screw with a screwdriver and remove the repair wrench from the bottom of the machine (or use a self-prepared screwdriver).

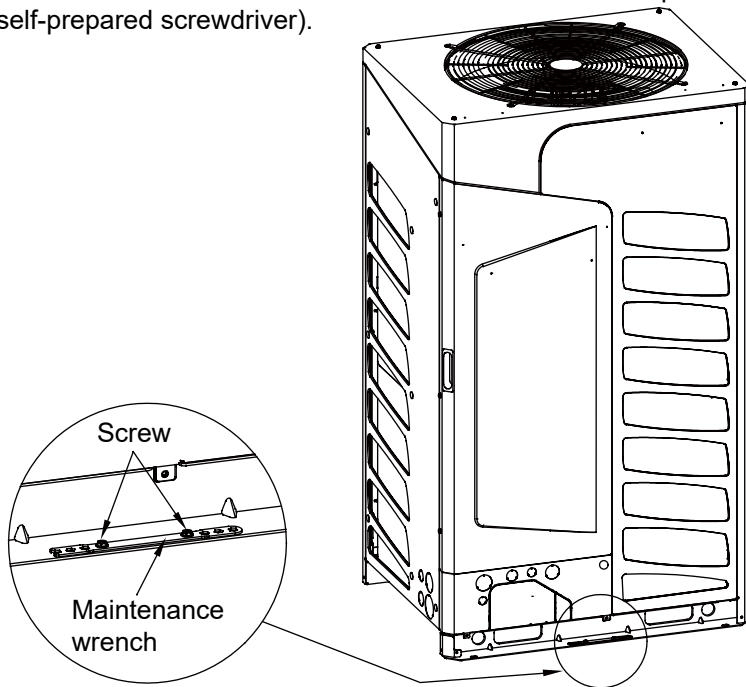

2. Remove the screw A, B, and C by rotating the wrench in the direction of the arrow.

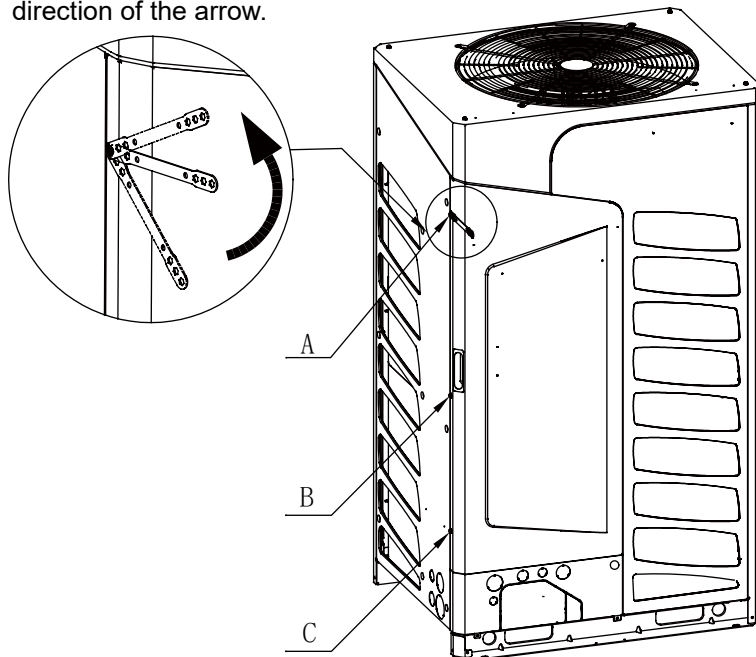

3. Along the direction of the arrow, after repair plate rotating about 40°, the maintenance from the fixed orifice plate on the right side of card claw, can complete repair plate disassembly.

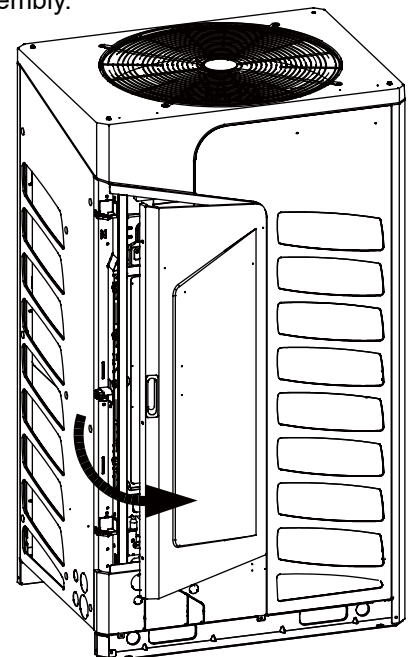

# Installation instruction

## Install air ducting

There are no obstacles in the 2000mm above the outdoor unit; When there are obstacles in the outer plane, there must be a pilot channel, and the wind will be free, the wind will not be short-circuited, and the external static pressure will be less than 110Pa. Airway design dimensions are as follows:

Channel size (pattern 1)

	AV08~14IMVURA	AV16~22IMVURA
A	The inner diameter 980	The inner diameter 1410
B	The inner diameter 750	The inner diameter 750
C	≤10000	≤10000
D	E+750	E+750
E	≥300	≥300
F	≥320	≥320

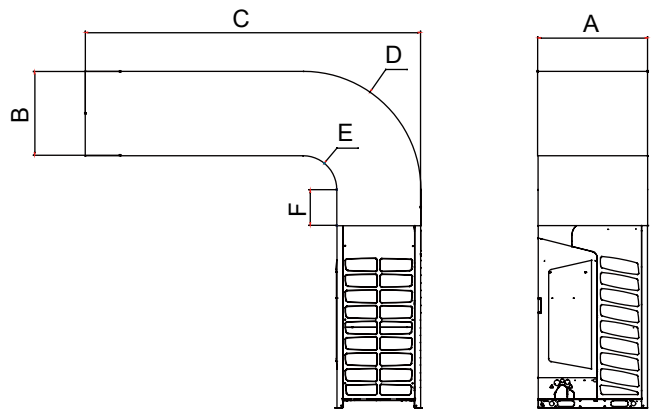

Channel size (pattern 2)

	AV08~14IMVURA	AV16~22IMVURA
A	The inner diameter 750	The inner diameter 750
B	The inner diameter 980	The inner diameter 1410
C	≤10000	≤10000
D	E+980	E+1410
E	≥300	≥300
F	≥320	≥320

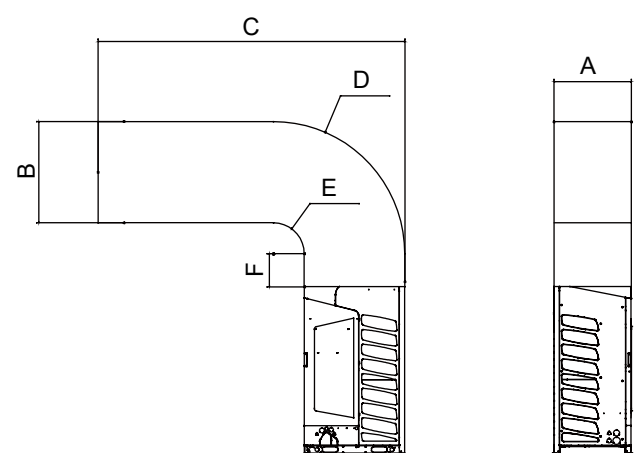

**Note:**  
 Before installing the wind channel, the unit should be removed from the wind protection network. At the same time, the outdoor air tube static press is set up to "have static pressure" mode. The above is just an example, the length of the wind tunnel should be calculated according to the shape of the wind channel.

# Installation procedure

## A. Refrigerant pipe connection

### Pipe connection method:

- To ensure the efficiency, the pipe should be as short as possible.
- Daub the refrigerant oil on the connector and the flare nut.
- When bending the pipe, the bending semi-diameter should be as large as possible against the pipe being broken or bent.
- When connecting the pipe, aim at the center to thread the nut by hand and tighten it with the double spanners.
- Fastening torque please refers to "pipe specs and fastening torque" on page 15.
- Don't let the impurity such as sand, water etc into the pipe. Antifouling measures refer to Page 13.

When fastening and loosening the nut, operate with double spanners, because only one spanner cannot execute firmly.

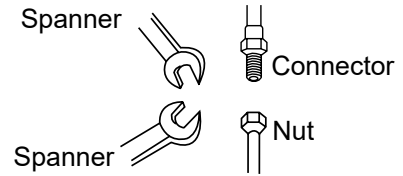

If threading the nut as not aiming at the center, the screw thread will be damaged, further it will cause leakage.

### Cautions in piping installation:

1. When welding the pipe with hard solder, charge nitrogen into the pipe against oxidation. The pressure gauge should be set at 0.02MPa. Perform the procedure with nitrogen circulation. Otherwise, the oxide film in the pipe may clog the capillary and expansion valve resulting in accident.
2. The refrigerant pipe should be clean. If the water and the other impurity enter the pipe, charge the nitrogen to clean the pipe. The nitrogen should flow under the pressure of about 0.5MPa and when charging the nitrogen, stop up the end of the pipe by hand to enhance the pressure in the pipe, then loose the hand (meanwhile stop up the other end).
3. The piping installation should be executed after closing the stop valves.
4. When welding the valve and the pipe, cool down the valve with wet towel.
5. When the connection pipe and the branch pipe need to be cut down, please use the special shears and do not use the saw.
6. When welding copper pipe, use the phosphor copper welding rod without any welding flux. (welding flux will damage the piping system. The welding flux containing chlorine will corrode pipe, especially, the welding flux with fluorin will damage refrigeration oil.)

### Pipe material and specs selection

1. Please select the refrigerant pipe of the below material.  
Material: the phosphoric oxidize seamless copper pipe, model: C1220T-1/2H (diameter is over 19.05); C1220T-0(diameter is below 15.88).
2. Thickness and specs:  
Confirm the pipe thickness and specs according to the pipe selection method(the unit is with R410A, if the pipe over 19.05 is O-type, the pressure preservation will be bad, thus it must be 1/2H type and over the min. thickness).
3. The branch pipe and the gather pipe must be from Haier.
4. When installing the stop valve, refer to the relative operation instruction.
5. The pipe installation should be in the allowable range.
6. The installation of branch pipe and gather pipe should be performed according to the relative manual.

### Anti-fouling measures

First, clean the pipe.

Position	Installation period	Measures
Outdoor	More than 1 month	Flat the pipe end
	Less than 1 month	
Indoor	Nothing to do with period	Flat the pipe end or seal with adhesive tape

# Installation procedure

## Pipe specification

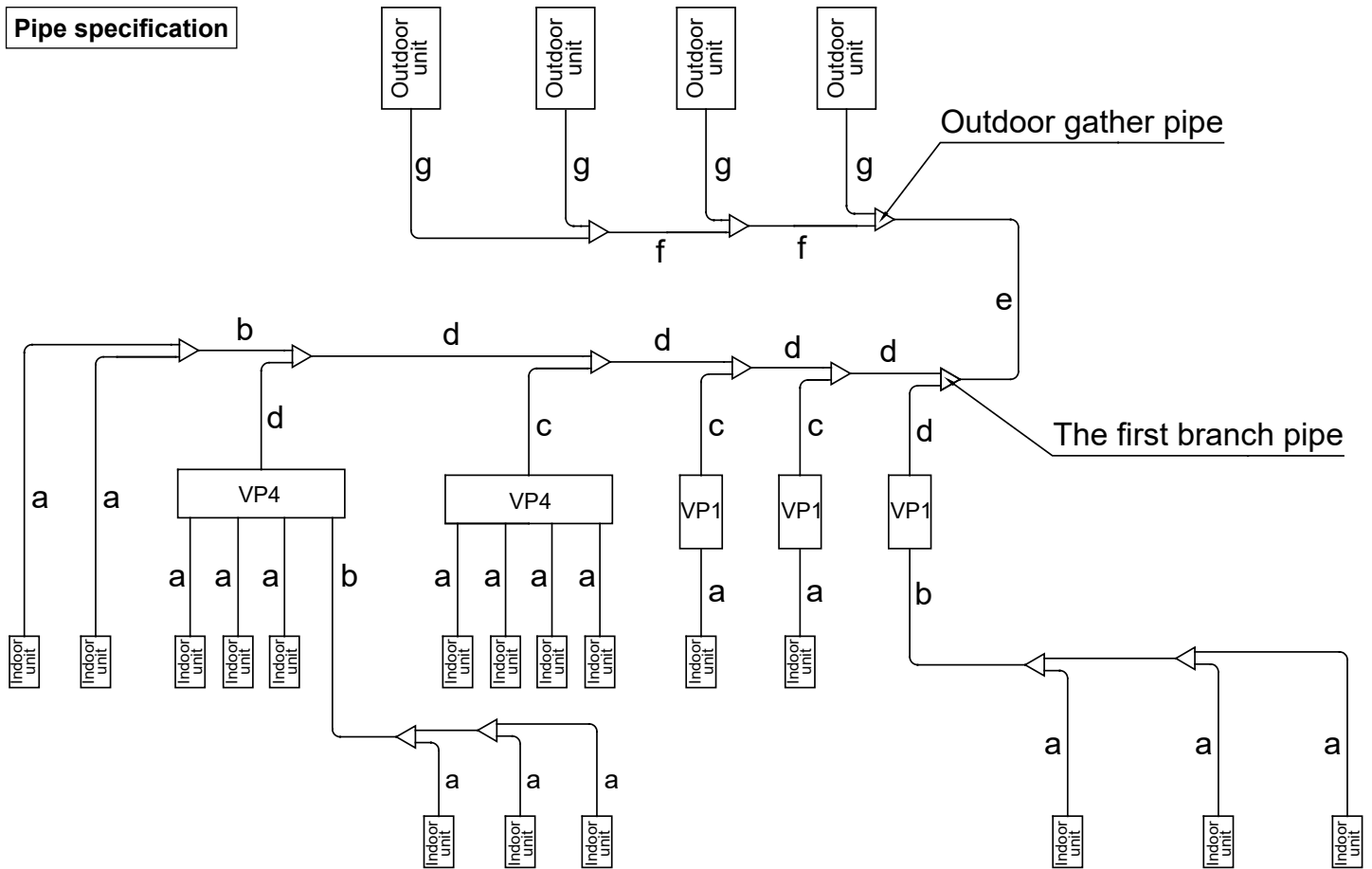

1. Pipe "a" diameter (between indoor and branch pipe) (depends on indoor pipe)

Indoor (x100W)	Gas pipe(mm)	Liquid pipe(mm)
22~28	Ø9.52	Ø6.35
36~56	Ø12.7	Ø6.35
71~140	Ø15.88	Ø9.52
226~300	Ø25.4	Ø9.52
450~600	Ø28.58	Ø12.7

Note:

AS072 AS092 gas pipe / liquid pipe: Ø12.7mm/6.35mm. AS182 gas pipe / liquid pipe: Ø15.88mm/9.52mm.

From the indoor to the shortest branch pipe unit  $\geq 15$ m, please change specifications of pipe as per the table below.

- ① When rated refrigerating  $\leq 5.6$ kW, change specifications of Gas pipe/Liquid pipe to Ø15.88mm/Ø9.52mm.
- ② When  $5.6$ kW < rated refrigerating <  $16.8$ kW, change specifications of Gas pipe/Liquid pipe to Ø19.05mm/Ø9.52mm.
- ③ When rated refrigerating >  $16.8$ kW, change specifications of Liquid pipe to Ø12.7mm.

2. Pipe "b" diameter (between branch pipes)

Total indoor capacity after the branch pipe (kW)	Gas pipe (mm)	Liquid pipe (mm)
$X < 16.8$ kW	Ø15.88	Ø9.52
$16.8$ kW $\leq X < 22.4$ kW	Ø19.05	Ø9.52
$22.4$ kW $\leq X < 33.5$ kW	Ø22.22	Ø9.52
$33.5$ kW $\leq X < 47.0$ kW	Ø28.58	Ø12.7
$47.0$ kW $\leq X < 71.0$ kW	Ø28.58	Ø15.88
$71.0$ kW $\leq X < 101.0$ kW	Ø31.8	Ø19.05
$\geq 101.0$ kW	Ø38.1	Ø19.05

Note: Adjust the diameter on field (changing pipe is needed)

# Installation procedure

## 3. Pipe "c" diameter (between VP and branch pipe) (depends on VP pipe)

VP	Suction gas pipe (mm)	HP gas pipe (mm)	Liquid pipe (mm)
112B	Ø15.88	Ø12.7	Ø9.52
180B	Ø15.88	Ø15.88	Ø9.52
280B	Ø22.22	Ø19.05	Ø9.52

## 4. Pipe "d" diameter (between VP branch pipes)

Total indoor capacity after the branch pipe (kW)	Suction gas pipe (mm)	HP gas pipe (mm)	Liquid pipe (mm)
X<16.8kW	Ø15.88	Ø12.7	Ø9.52
16.8kW≤X<22.4kW	Ø19.05	Ø15.88	Ø9.52
22.4kW≤X<33.5kW	Ø22.22	Ø19.05	Ø9.52
33.5kW≤X<47.0kW	Ø28.58	Ø25.4	Ø12.7
47.0kW≤X<71.0kW	Ø28.58	Ø25.4	Ø15.88
71.0kW≤X<101.0kW	Ø31.8	Ø28.58	Ø19.05
≥101.0kW	Ø38.1	Ø31.8	Ø19.05

## 5. Pipe "e" diameter (main pipe, between outdoor gather pipe and the first branch pipe)

Outdoor capacity (HP)	Outdoor capacity (kW)	Main pipe			Enlarged main pipe		
		Suction gas pipe(mm)	HP gas pipe(mm)	Liquid pipe(mm)	Suction gas pipe(mm)	HP gas pipe(mm)	Liquid pipe(mm)
8	22.4	Ø19.05	Ø19.05	Ø9.52	Ø22.22	Ø22.22	Ø12.70
10	28.0	Ø22.22	Ø19.05	Ø9.52	Ø25.40	Ø22.22	Ø12.70
12	33.5	Ø25.40	Ø22.22	Ø12.70	Ø28.58	Ø25.40	Ø15.88
14	40.0	Ø25.40	Ø22.22	Ø12.70	Ø28.58	Ø25.40	Ø15.88
16	45.0	Ø28.58	Ø25.40	Ø12.70	Ø31.80	Ø28.58	Ø15.88
18	50.4	Ø28.58	Ø25.40	Ø15.88	Ø31.80	Ø28.58	Ø19.05
20	56.0	Ø28.58	Ø25.40	Ø15.88	Ø31.80	Ø28.58	Ø19.05
22	61.5	Ø28.58	Ø25.40	Ø15.88	Ø31.80	Ø28.58	Ø19.05
24	68.0	Ø28.58	Ø25.40	Ø15.88	Ø31.80	Ø28.58	Ø19.05
26	73.5	Ø28.58	Ø25.40	Ø15.88	Ø31.80	Ø28.58	Ø19.05
28	80.0	Ø28.58	Ø25.40	Ø15.88	Ø31.80	Ø28.58	Ø19.05
30	85.0	Ø31.80	Ø28.58	Ø19.05	Ø34.90	Ø31.80	Ø22.22
32	90.0	Ø31.80	Ø28.58	Ø19.05	Ø34.90	Ø31.80	Ø22.22
34	95.4	Ø31.80	Ø28.58	Ø19.05	Ø34.90	Ø31.80	Ø22.22
36	100.8	Ø38.10	Ø34.90	Ø19.05	Ø41.30	Ø38.10	Ø22.22
38	106.4	Ø38.10	Ø34.90	Ø19.05	Ø41.30	Ø38.10	Ø22.22
40	112.0	Ø38.10	Ø34.90	Ø19.05	Ø41.30	Ø38.10	Ø22.22
42	117.5	Ø38.10	Ø34.90	Ø19.05	Ø41.30	Ø38.10	Ø22.22
44	123.0	Ø38.10	Ø34.90	Ø19.05	Ø41.30	Ø38.10	Ø22.22
46	130.0	Ø38.10	Ø34.90	Ø19.05	Ø41.30	Ø38.10	Ø22.22
48	135.0	Ø38.10	Ø34.90	Ø19.05	Ø41.30	Ø38.10	Ø22.22
50	140.4	Ø38.10	Ø34.90	Ø19.05	Ø41.30	Ø38.10	Ø22.22
52	145.8	Ø38.10	Ø34.90	Ø19.05	Ø41.30	Ø38.10	Ø22.22
54	151.2	Ø38.10	Ø34.90	Ø19.05	Ø41.30	Ø38.10	Ø22.22
56	156.8	Ø38.10	Ø34.90	Ø19.05	Ø41.30	Ø38.10	Ø22.22
58	162.4	Ø41.30	Ø38.10	Ø19.05	Ø44.50	Ø41.30	Ø22.22
60	168.0	Ø41.30	Ø38.10	Ø19.05	Ø44.50	Ø41.30	Ø22.22

# Installation procedure

Outdoor capacity (HP)	Outdoor capacity (kW)	Main pipe			Enlarged main pipe		
		Suction gas pipe(mm)	HP gas pipe(mm)	Liquid pipe(mm)	Suction gas pipe(mm)	HP gas pipe(mm)	Liquid pipe(mm)
62	173.5	Ø41.30	Ø38.10	Ø19.05	Ø44.50	Ø41.30	Ø22.22
64	179.0	Ø41.30	Ø38.10	Ø19.05	Ø44.50	Ø41.30	Ø22.22
66	184.5	Ø41.30	Ø38.10	Ø19.05	Ø44.50	Ø41.30	Ø22.22
68	190.8	Ø44.50	Ø41.30	Ø22.22	Ø50.80	Ø44.50	Ø25.40
70	196.2	Ø44.50	Ø41.30	Ø22.22	Ø50.80	Ø44.50	Ø25.40
72	201.6	Ø44.50	Ø41.30	Ø22.22	Ø50.80	Ø44.50	Ø25.40
74	207.2	Ø44.50	Ø41.30	Ø22.22	Ø50.80	Ø44.50	Ø25.40
76	212.8	Ø44.50	Ø41.30	Ø22.22	Ø50.80	Ø44.50	Ø25.40
78	218.4	Ø44.50	Ø41.30	Ø22.22	Ø50.80	Ø44.50	Ø25.40
80	224.0	Ø44.50	Ø41.30	Ø22.22	Ø50.80	Ø44.50	Ø25.40
82	229.5	Ø44.50	Ø41.30	Ø22.22	Ø50.80	Ø44.50	Ø25.40
84	235.0	Ø44.50	Ø41.30	Ø22.22	Ø50.80	Ø44.50	Ø25.40
86	240.5	Ø50.80	Ø44.50	Ø25.40	Ø54.10	Ø50.80	Ø25.40
88	246.0	Ø50.80	Ø44.50	Ø25.40	Ø54.10	Ø50.80	Ø25.40

Note: When the distance from outdoor to the longest indoor is over 90m, the main pipe should be the enlarged diameter.

## 6. Pipe "f" diameter (between gather pipes)

Total outdoor capacity before gather pipe	Suction gas pipe(mm)	HP gas pipe(mm)	Liquid pipe(mm)
16HP	Ø28.58	Ø25.40	Ø12.70
18~28HP	Ø28.58	Ø25.40	Ø15.88
30~34HP	Ø31.80	Ø28.58	Ø19.05
36~56HP	Ø38.10	Ø34.90	Ø19.05
58~66HP	Ø41.30	Ø38.10	Ø19.05
68~84HP	Ø44.50	Ø41.30	Ø22.22
86~88HP	Ø50.80	Ø44.50	Ø25.40

## 7. Pipe "g" diameter (between outdoor and the gather pipe)

Outdoor capacity	Suction gas pipe(mm)	HP gas pipe(mm)	Liquid pipe(mm)
8HP	Ø19.05	Ø19.05	Ø9.52
10HP	Ø22.22	Ø19.05	Ø9.52
12/14HP	Ø25.40	Ø22.22	Ø12.70
16HP	Ø28.58	Ø25.40	Ø12.70
18/20/22HP	Ø28.58	Ø25.40	Ø19.05

## Copper pipe selection:

Material	O type pipe: Soft pipe				
Pipe diameter (mm)	Ø6.35	Ø9.52	Ø12.7	Ø15.88	Ø19.05
Thickness(mm)	0.8	0.8	1.0	1.0	1.1

Material	Hard pipe							
Pipe diameter (mm)	Ø19.05	Ø22.22	Ø25.4	Ø28.58	Ø31.8	Ø34.9	Ø38.1	Ø41.3
Thickness(mm)	1.0	1.0	1.0	1.0	1.1	1.3	1.4	1.5

# Installation procedure

## Long pipe and high drop

### 1. Allowable piping length and drop between indoor and outdoor

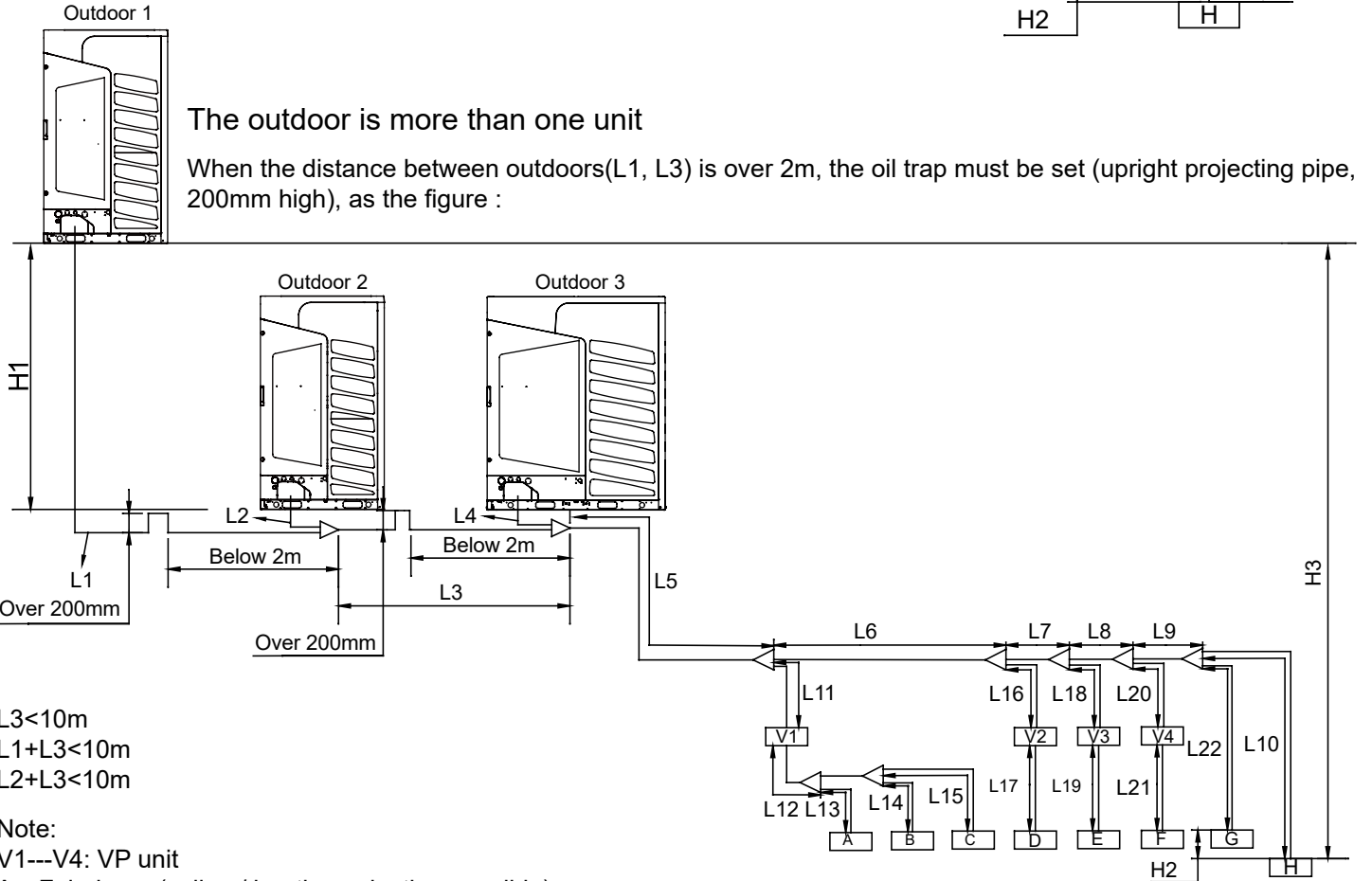
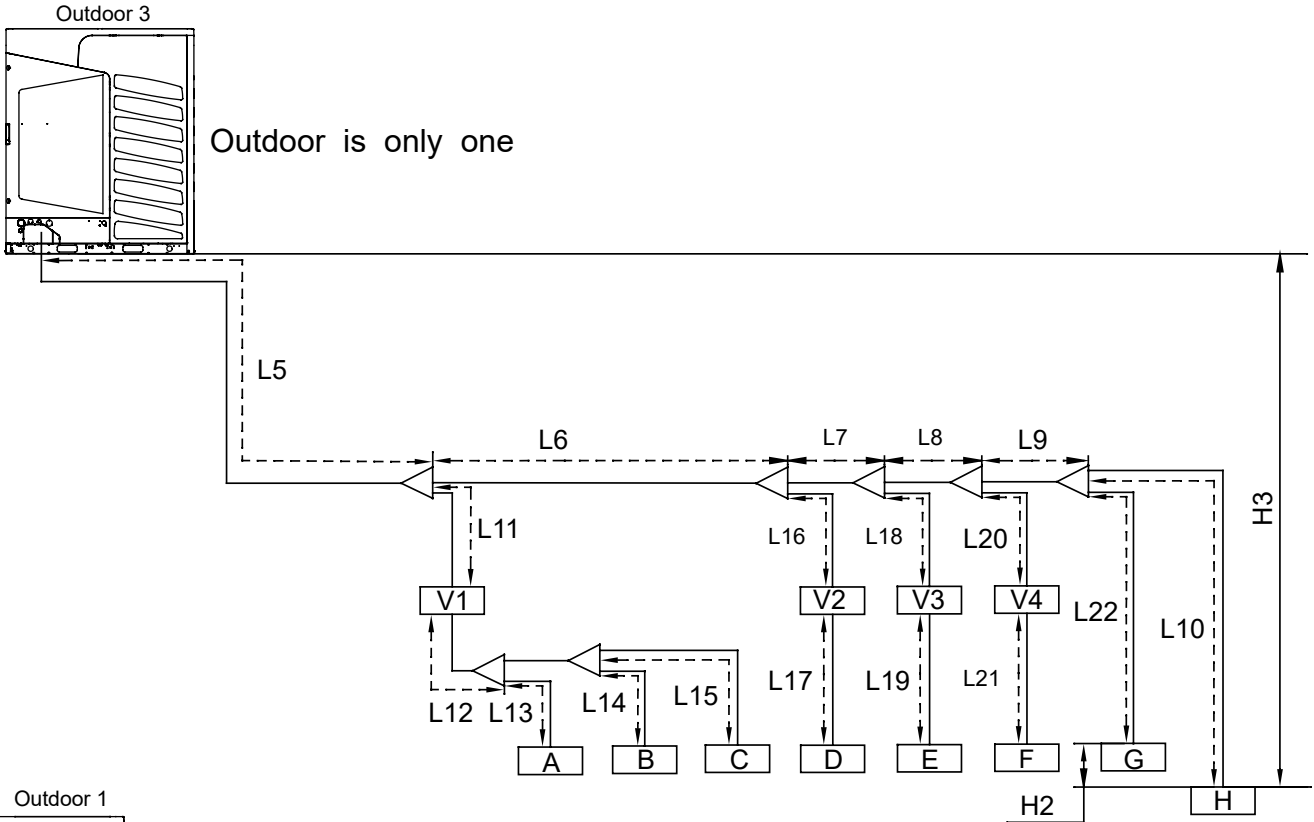

- L3 < 10m
- L1 + L3 < 10m
- L2 + L3 < 10m

Note:

V1---V4: VP unit

A---F: indoors (cooling / heating selection possible)

G---H: indoors (cooling only)

# Installation procedure

## 2. Applicable range

Item	Model	All outdoors	Pipe in above figure
Single way total pipe length		1000 m (correspond length)	L1+L2+L3.....+L22
Single way pipe length		Max. 165/190 (correspond length)	L1+L3+ L5+L6+L7+L8+L9+L10
Main pipe between outdoor to 1st branch		Max.130 (correspond length)	L5
Height difference between indoor and outdoor	Outdoor is upper	Max. 40m	H3
	Outdoor is lower	Max. 50m	H3
Height difference between outdoors (in the same system)		Within 0.5 m (better be horizontal)	H1
Max. pipe length from 1st branch pipe to indoor		Max. 40m	L6+L7+L8+L9+L10
Height difference between indoors		Max. 15m	H2
Max. pipe length between indoors and the nearest branch pipe		Max. 30m	

When outdoor is only one,  
 Single way max. pipe length =  $L5+L6+L7+L8+L9+L10 \leq 190\text{m}$   
 Single way total pipe length =  $L5+L6.....+L22$

When the pipe between the outdoor unit and its furthest indoor unit is longer than 90m, the specification of master pipe (Gas pipe/ Liquid pipe) between outdoor unit and the first Y joint should be upgraded for one level. For more details, please refer to "*Outdoor pipe selection table*"

When the pipe between the first Y joint and its furthest indoor unit is longer than 40m,

- (1) The specification of the master pipe ( Gas pipe/ Liquid pipe) between the first Y joint and its furthest indoor unit should be upgraded for one level.
- (2) The distance between the furthest indoor unit and the nearest one  $\leq 40\text{m}$ .

## 3. Pipe length between outdoors

- (1) The piping connecting outdoor unit must be placed horizontally or in accordance with the installation of a certain angle (level angle less than 15 degrees), connected with a concave not allowed.
- (2) All piping cannot connect the outdoor unit is higher than the height of the machine outlet (valve interface part).

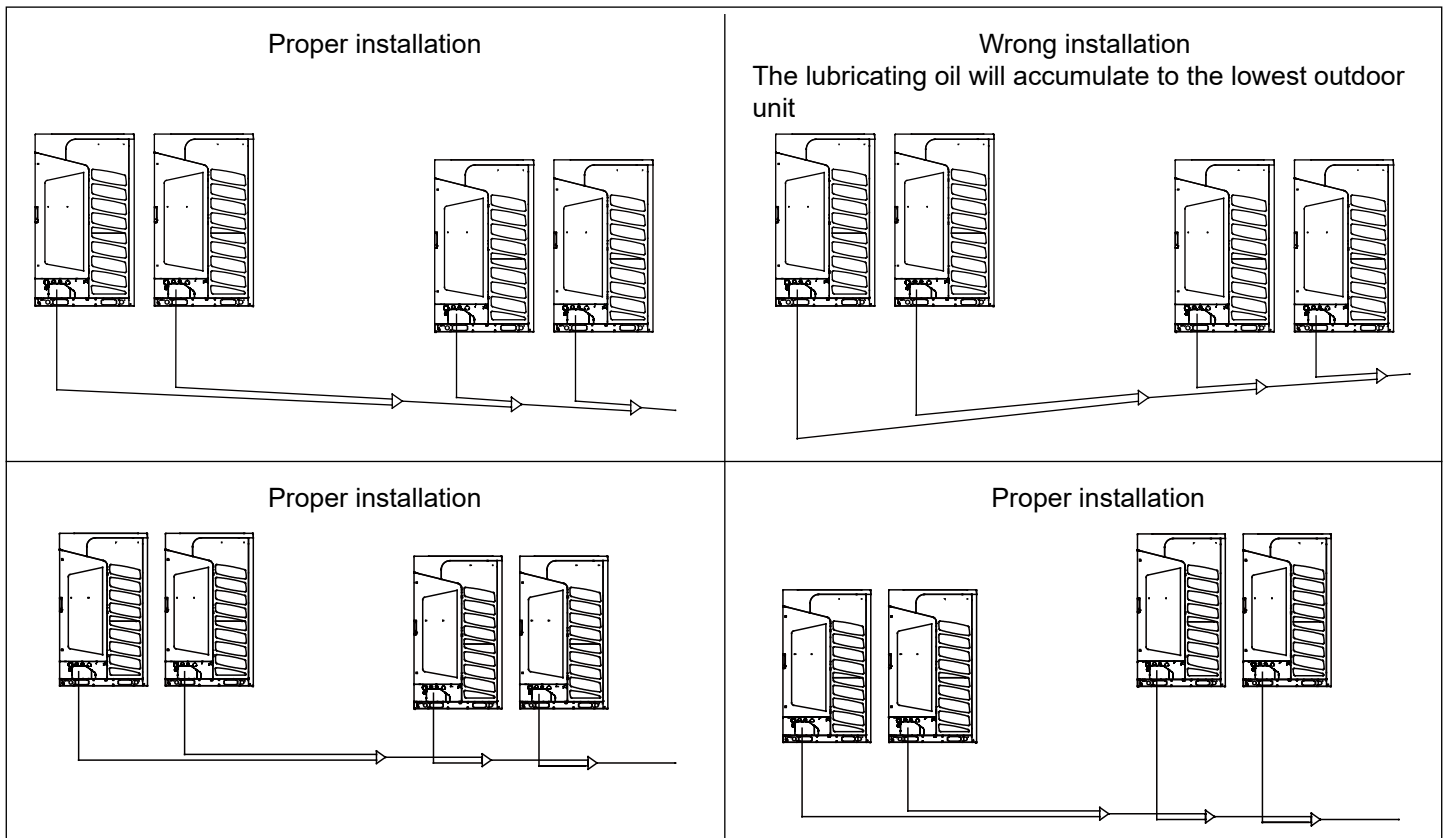



# Installation procedure

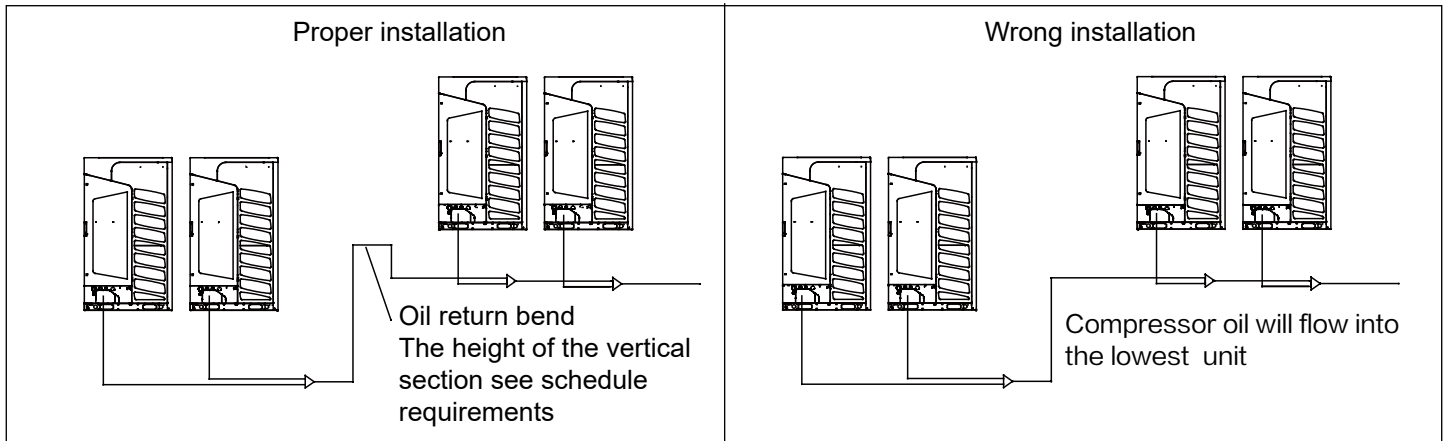

In order to avoid damage to the pipe, the size of the return bend is referred to as the drawing.

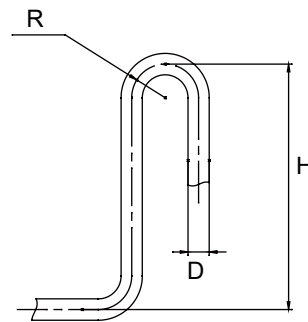
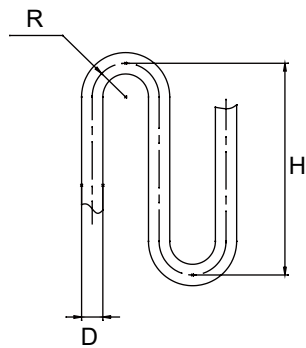

Pipe diameter D	Bending radius R	Vertical heigh H
Ø19.05	≥31	≤150
Ø22.22	≥31	≤150
Ø25.4	≥45	≤150
Ø28.58	≥45	≤150
Ø31.8	≥60	≤250
Ø38.1	≥60	≤350
Ø41.3	≥80	≤450
Ø44.5	≥80	≤500
Ø50.8	≥90	≤500
Ø54.1	≥90	≤500

# Installation procedure

## 4. Example of connection

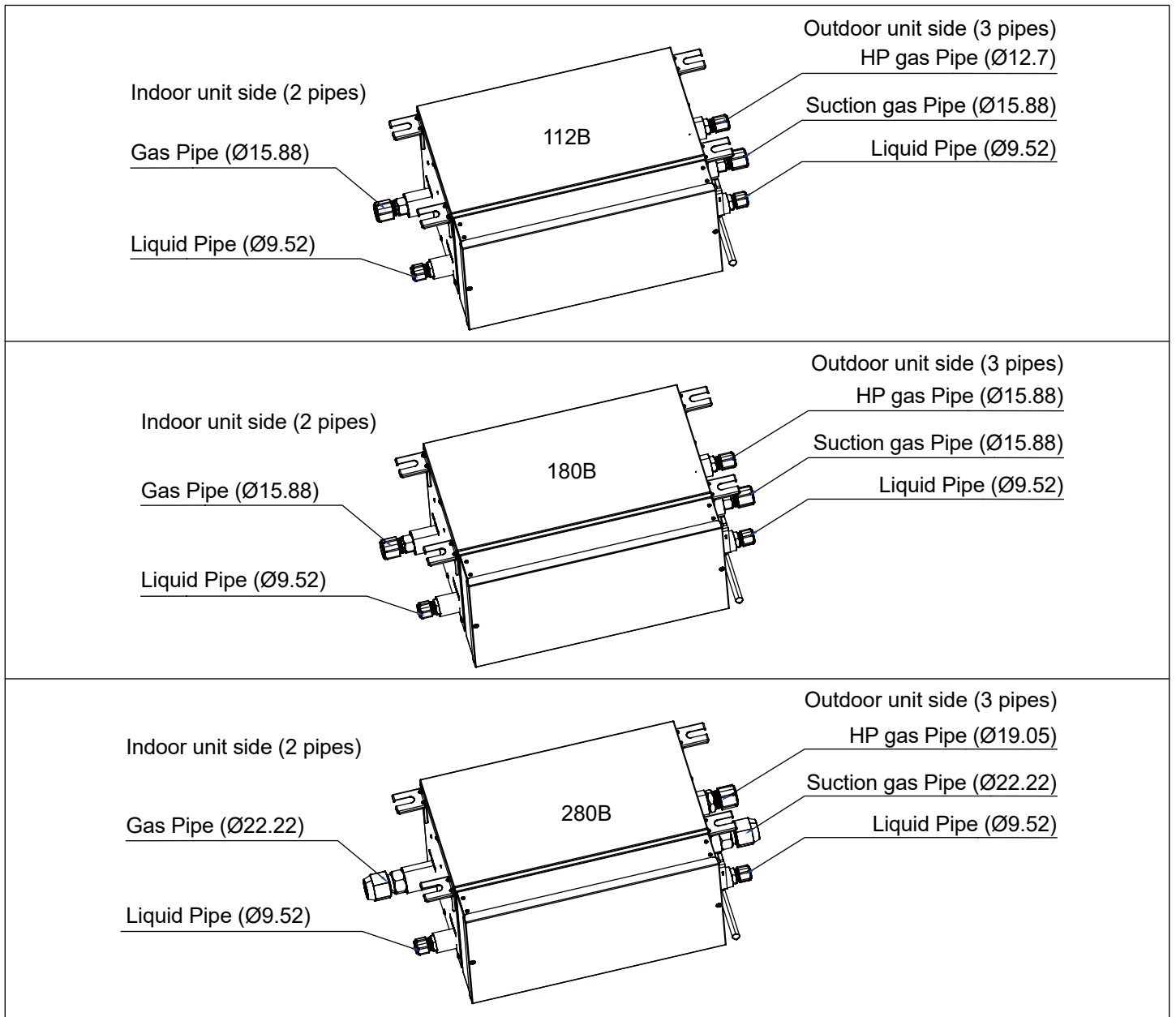

# Installation procedure

## Outdoor pipe dimension

24~44HP

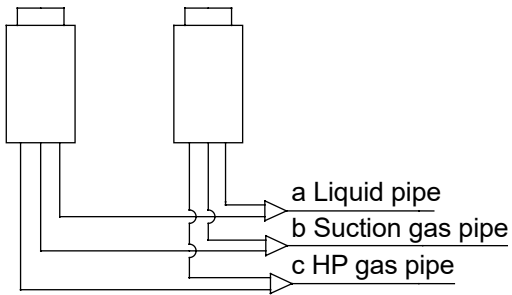

46~66HP

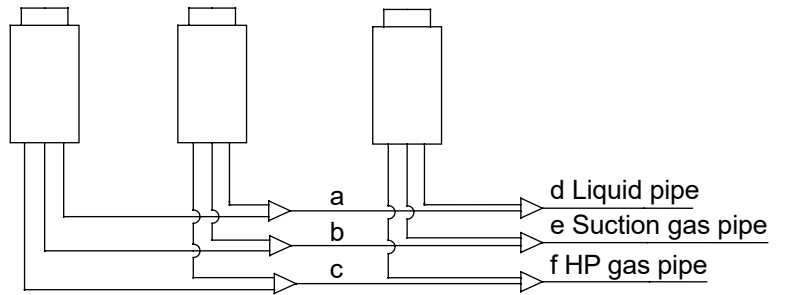

68~88HP

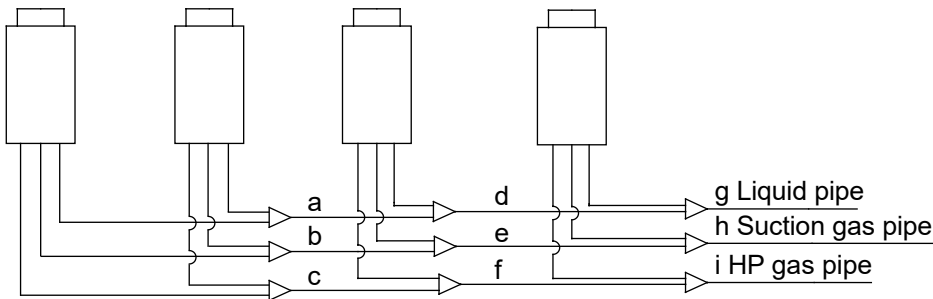

The pipe "a, b, c, d, e, f, g, h, i" should be confirmed as to the below table

Total outdoor capacity before gather pipe (kW)	Suction gas pipe (a,d,g) (mm)	HP gas pipe (b,e,h) (mm)	Liquid pipe (c,f,i) (mm)
45.0	φ28.58	φ25.40	φ12.70
50.4~80	φ28.58	φ25.40	φ15.88
85~95.4	φ31.80	φ28.58	φ19.05
100.8~156.8	φ38.10	φ34.90	φ19.05
162.4~184.5	φ41.30	φ38.10	φ19.05
191.0~236	φ44.50	φ41.30	φ22.22
241.5~248.0	φ50.80	φ44.50	φ25.40

## Unit pipe spec and connection method (unit: mm)

### A. Outdoor unit

Model	HP gas pip		Suction gas pip		Liquid pipe	
	Diameter (mm)	Connection method	Diameter (mm)	Connection method	Diameter (mm)	Connection method
AV08IMVURA	Ø19.05	Flared	Ø19.05	Flared	Ø9.52	Flared
AV10IMVURA	Ø19.05		Ø22.22		Ø9.52	
AV12IMVURA	Ø22.22	Braze	Ø25.4	Braze	Ø12.7	
AV14IMVURA	Ø22.22		Ø25.4		Ø12.7	
AV16IMVURA	Ø25.4		Ø28.58		Ø12.7	
AV18IMVURA	Ø25.4		Ø28.58		Ø15.88	
AV20IMVURA	Ø25.4		Ø28.58		Ø15.88	
AV22IMVURA	Ø25.4		Ø28.58		Ø15.88	

# Installation procedure

## B. Indoor unit

Model	Gas pipe side		Liquid pipe side	
	Diameter (mm)	Connecting method	Diameter (mm)	Connecting method
07	Ø9.52	Flared	Ø6.35	Flared
09	Ø9.52		Ø6.35	
12	Ø12.7		Ø6.35	
16	Ø12.7		Ø6.35	
18	Ø12.7		Ø6.35	
24	Ø15.88		Ø9.52	
28	Ø15.88		Ø9.52	
30	Ø15.88		Ø9.52	
38	Ø15.88		Ø9.52	
48	Ø15.88		Ø9.52	

Note:

AS072 AS092 gas pipe / liquid pipe: Ø12.7mm/6.35mm;

AS182 gas pipe / liquid pipe: Ø15.88/9.52mm

### Branch pipe

Branch pipe selection:

Total indoor capacity (100W)	Model(optional)	
	3 pipes	2 Pipes
$X < 335$	FQG-R335A	FQG-B335A
$335 \leq X < 506$	FQG-R506A	FQG-B506A
$506 \leq X < 730$	FQG-R730A	FQG-B730A
$730 \leq X < 1350$	FQG-R1350A	FQG-B1350A
$X \geq 1350$	FQG-R2040A	FQG-B2040A

Outdoor unit type

The master unit will choose the closest one to the 1st branch pipe.

Note:

- When connecting the gather pipe and the outdoor, please pay attention to the outdoor pipe dimension.
- When adjusting the diameter among gather pipes and among the units, please must execute at the branch pipe side.
- Please install the gather pipe(gas/liqiud side) in horizontal or vertical direction.
- When welding with hard solder, please must blow nitrogen. If not, a number of oxide will be produced and cause heavy damage.Besides,to prevent water and dust into the pipe, please make the brim as outer roll.

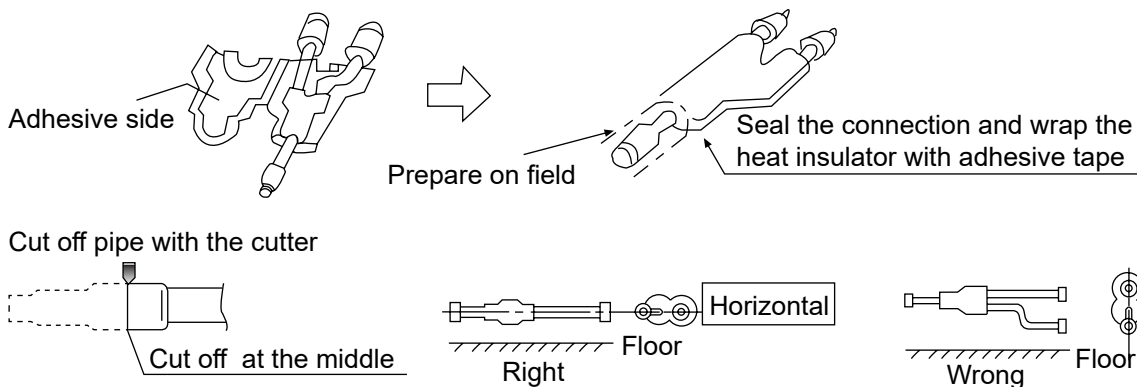

## C. Pipe spec and the torque

Diameter (mm)	Torque(N·m)
Ø6.35	16~20
Ø9.52	40~50
Ø12.7	40~50
Ø15.88	90~120
Ø19.05	100~140
Not less than Ø22.22	No requirement, due to braze connector

# Installation procedure

## Pipe installation

### Important

- Please don't let the pipe and the parts in the unit collide each other.
- When connecting the pipes, close the valves fully.
- Protect the pipe end against the water, impurity into the pipes (welding after being flat, or being sealed with adhesive tape).
- Bend the pipe as large semi-diameter as possible(over 4 times of the pipe diameter).
- The connection between outdoor liquid pipe and the distributing pipe is flared type. Please expand the pipe with the special tool for R410A after installing the expanding nut. But if the projecting pipe length has been adjusted with the copper pipe gauge, you can use the original tool to expand the pipe.
- Since the unit is with R410A, the expanding oil is ester oil, not the mineral oil.
- When connecting the expanding pipe, fasten the pipes with double-spanner. The torque refers to the former info.

Expanding pipe: A(mm)		Projecting length of pipe to be expanded: B(mm)		
Pipe outer diameter (mm)	A 0 -0.4	Pipe outer diameter (mm)	When it is hard pipe	
Ø6.35	9.1		Special tool for R410A	The former tool
Ø9.52	13.2		0-0.5	1.0-1.5
Ø12.7	16.6			
Ø15.88	19.7			

- The outdoor gas pipe and the refrigerant distributing pipe, as well the refrigerant distributing pipe and the branch pipe should be welded with hard solder.
- Weld the pipe at the same time charge the nitrogen. Or it will cause a number of impurity (a film of oxidation) to clog the capillary and the expansion valve, further cause the deadly failure.

### Operation procedure

- Weld the pipe at the same time charge the nitrogen. Or it will cause a number of impurity (a film of oxidation) to clog the capillary and the expansion valve, further cause the deadly failure.

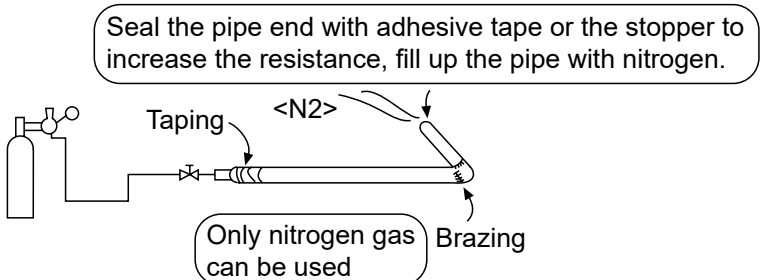

Seal the pipe end with adhesive tape or the stopper to increase the resistance, fill up the pipe with nitrogen.

Taping <N2> Brazing

Only nitrogen gas can be used

---

- Protect the pipe end against water and impurities (welding after being flattened, or being sealed with adhesive tape).

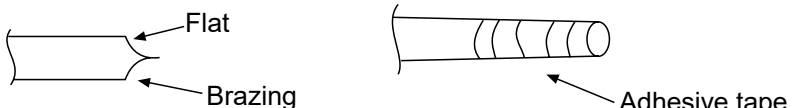

Flat  
Brazing  
Adhesive tape

---

- The refrigerant pipe should be clean. The nitrogen should flow under the pressure of about 0.5MPa and when charging the nitrogen, stop up the end of the pipe by hand to enhance the pressure in the pipe, then loose the hand (meanwhile stop up the other end).

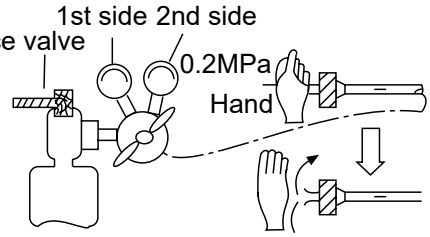

Source valve 1st side 2nd side  
0.2MPa Hand

---

- When connecting the pipes, close the valves fully.
- When welding the valve and the pipes, use the wet cloth to cool down the valve and the pipes.

# Installation procedure

## B. Leakage test

1. The outdoor unit has been executed the leakage test in the factory. The pipe should be executed leakage test individually and forbidden to test after connecting with stop valve.
2. Refer to the below figure to charge the nitrogen into the unit to take a test. Never use the chlorine, oxygen, flammable gas in the leakage test. Apply pressure both on the gas pipe and the liquid pipe.
3. Apply the pressure step by step to the target pressure.
  - a. Apply the pressure to 0.5MPa for more than 5 minutes, confirm if pressure goes down.
  - b. Apply the pressure to 1.5MPa for more than 5 minutes, confirm if pressure goes down.
  - c. Apply the pressure to the target pressure (4.15MPa), record the temp. and the pressure.
  - d. Leave it at 4.15MPa for over 1 day, if pressure does not go down, the test is passed. Meanwhile, when the temp. changes for 1 degree, pressure will change 0.01MPa as well. Correct the pressure.
  - e. After confirmation of a~d, if pressure goes down, there is leakage. Check the brazing position, flared position by laying on the soap. Modify the leakage point and take another leakage test.
4. After leakage test, do execute the evacuation.

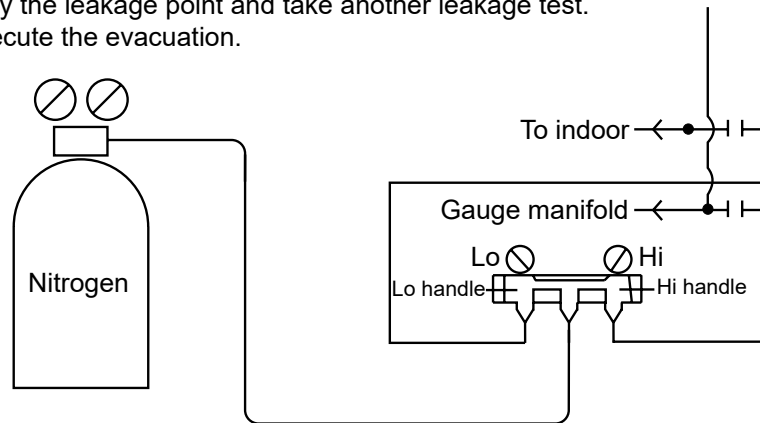

## C. Evacuation

Evacuate at the check valve of liquid stop valve and both sides of the gas stop valve. The oil equalization pipe also must be vacuum (executed at the oil equalization pipe and check valve respectively).

Operation procedure:

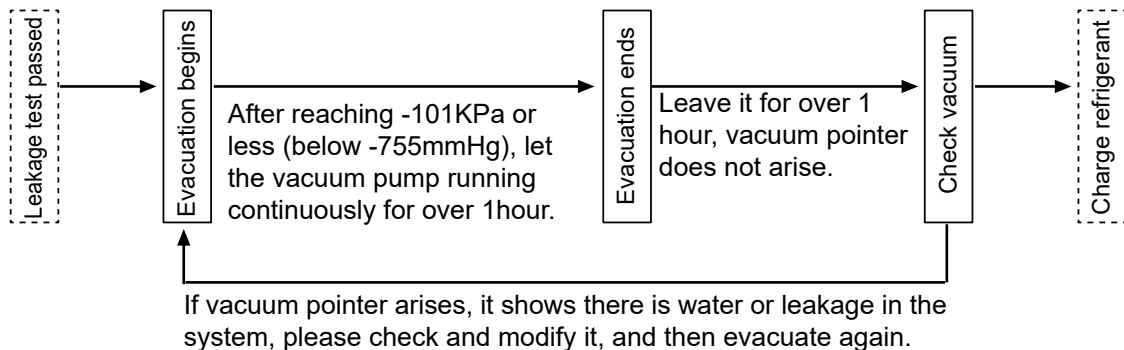

Because the unit is with refrigerant R410A, the below issues should be paid attention:

- To prevent the oil going into the pipe, please use the special tool for R410A, especially for gauge manifold and charging hose.
- To prevent the oil going into the refrigerant cycle, please use the anti-counter-flow adapter.
- When maintaining the outdoor, release refrigerant from check valve. When taking vacuum evacuation, set the relative dip switch. The details refer to Code section.

# Installation procedure

## D. Check valve operation

Open/ close method: (The suction gas pipe stop valve for AV08IMVURA, AV10IMVURA, AV12IMVURA, AV14IMVURA, AV16IMVURA, AV18IMVURA, AV20IMVURA, AV22IMVURA)

- Take down the valve cap, suction gas pipe, HP gas pipe turns to "open"
- Turn the liquid pipe and the oil equalization pipe with hexangular spanner until it stops. If opening the valve strongly, the valve will be damaged.
- Tighten the valve cap.

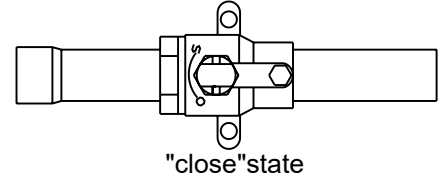
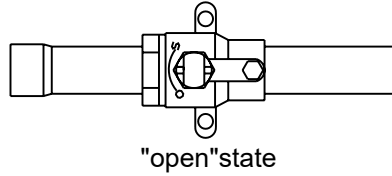

Tighten torque as the table below:

Tighten torque N·m			
	Shaft (valve body)	Cap (cover)	T-shape nut (check joint)
For suction gas pipe and HP gas pipe	Less than 7	Less than 30	13
For liquid pipe	7.85 (MAX15.7)	29.4 (MAX39.2)	8.8 (MAX14.7)
For oil equalization pipe	4.9 (MAX11.8)	16.2 (MAX24.5)	8.8 (MAX14.7)

## E. Additional refrigerant charging

Charge the additional refrigerant as liquid state with the gauge.

If the additional refrigerant can not be charged totally when the outdoor stops, charge it at the trial mode.

If the unit runs for a long period in the state of lack of refrigerant, compressor will occur failure.

( the charging must be finished within 30 minutes especially when the unit is running, meanwhile charging the refrigerant).

The unit is charged only part of the refrigerant at the factory, also need additional refrigerant at the installation site.

W1: Refrigerant charging volume to outdoor unit at factory.

W2: Refrigerant charging volume to outdoor unit on site.

W3: Refrigerant charging volume to liquid pipe base on different piping length calculation.

W3=actual length of liquid pipe×additional amount per meter liquid pipe=

$L1 \times 0.35 + L2 \times 0.25 + L3 \times 0.17 + L4 \times 0.11 + L5 \times 0.054 + L6 \times 0.022$

L1: Total length of 22.22 liquid pipe; L2: Total length of 19.05 liquid pipe;

L3: Total length of 15.88 liquid pipe; L4: Total length of 12.7 liquid pipe;

L5: Total length of 9.52 liquid pipe; L6: Total length of 6.35 liquid pipe;

Total refrigerant volume charging on site during installation=W2+W3

W: Total refrigerant volume charging on site for maintenance.

Refrigerant record form						
Model	W1: Refrigerant charging volume to outdoor unit at factory	W2: Refrigerant charging volume to outdoor unit on site	W3: Refrigerant charging volume to liquid pipe base on different piping length calculation		Total refrigerant volume charging on site during installation	W: Total refrigerant volume charging on site for maintenance
			Liquid pipe diameter (mm)	Additional refrigerant amount (kg)		
AV08IMVURA	10kg	1.0kg	Ø9.52	0.054kg/m×__m=__kg	W2+W3=__kg	W1+W2+W3=__kg
AV10IMVURA	10kg	1.0kg	Ø9.52	0.054kg/m×__m=__kg		
AV12IMVURA	10kg	2.5kg	Ø12.7	0.11kg/m×__m=__kg		
AV14IMVURA	10kg	2.5kg	Ø12.7	0.11kg/m×__m=__kg		
AV16IMVURA	10kg	5.5kg	Ø12.7	0.11kg/m×__m=__kg		
AV18IMVURA	10kg	5.5kg	Ø15.88	0.17kg/m×__m=__kg		
AV20IMVURA	10kg	7.0kg	Ø15.88	0.17kg/m×__m=__kg		
AV22IMVURA	10kg	7.0kg	Ø15.88	0.17kg/m×__m=__kg		
				W3=__kg		

# Installation procedure

Note:

- To prevent the oil going into the pipe, please use the special tool for R410A, especially for gauge manifold and charging hose.
- Mark the refrigerant type in different colour on the tank. R410A is pink.
- Must not use the charging cylinder, because the R410A will change when transferring to the cylinder.
- When charging refrigerant, the refrigerant should be taken out from the tank as liquid state.
- Mark the counted refrigerant volume due to the distributing pipe length on the label.

GWP: 2088

The product contains fluorinated greenhouse gases and its functioning relies upon such gases.

## Heat insulation

- HP gas pipe, Suction gas pipe and liquid pipe should be heat insulated separately.
- The material for HP gas pipe and Suction gas pipe should endure the high temperature over 120°C. That for liquid pipe should be over 70°C.
- The material thickness should be over 10mm, when ambient temp. is 30°C, and the relative humidity is over 80%, the material thickness should be over 20mm.
- The material should cling the pipe closely without gap, then be wrapped with adhesive tape. The connection wire can not be put together with the heat insulation material and should be far at least 20cm.

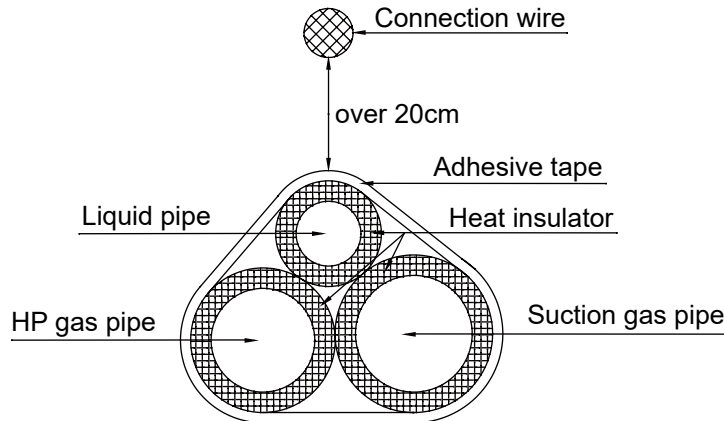

## Fix the refrigerant pipe

- In operation, the pipe will vibrate and expand or shrink.  
If not being fixed, the refrigerant will focus on one part to cause the broken pipe.
- To prevent the stress concentration, fix the pipe for every 2-3m.



# Electric wiring and the application

**Note:**

1. Please follow the national electrical standards, all provided parts, raw materials must comply with local laws and regulations. And please professional electrician installation.
2. Power supply must use the rated voltage and air conditioning unit dedicated power supply, power fluctuations in the power supply ratio of less than 2%, and were designed indoor unit, outdoor machine dedicated power.
3. The power cord should be reliably fastened to prevent the terminals from being stressed. Please do not force the power cord.
4. The power line diameter should be large enough, the ground wire should be reliable, should be connected to the building's special grounding device.
5. The air switch and earth leakage switch that can be cut off the entire system must be installed. Air switch should also have a magnetic trip and thermal trip function to ensure that short circuit and overload are protected, Should use "D" type circuit breaker.
6. Do not add the phase-connected capacitor to prevent overheating of the capacitor due to high frequency waves.
7. Please follow the instructions in accordance with the requirements of the power cord connection, so as to avoid a security incident.
8. The unit must be reliably grounded to meet the relevant requirements of GB 50169.
9. All electrical installations must be carried out by professionals in accordance with local laws, regulations and corresponding instructions.

**Power**

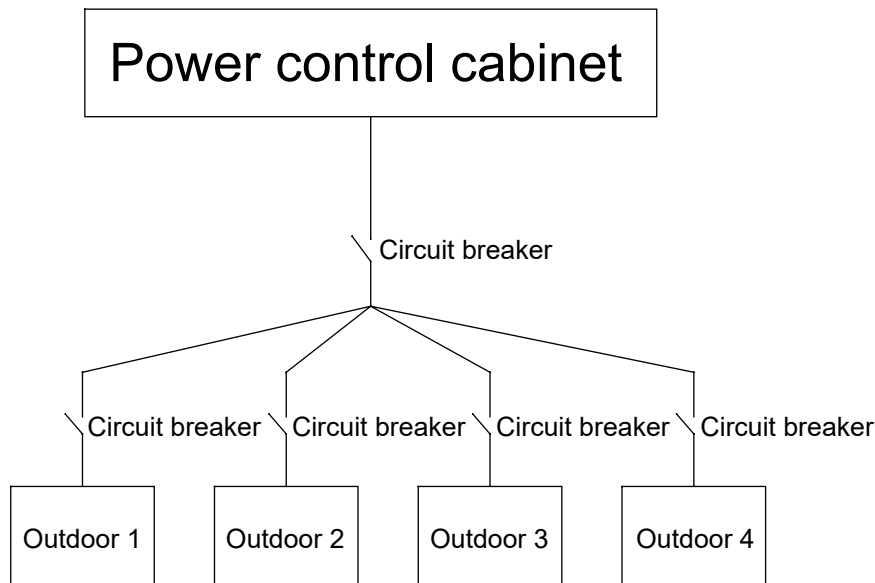

**Outdoor unit leakage protection switch and circuit breaker**

Model	Power source	Maximum load current (A)	Circuit breaker	Each module circuit breaker	Leakage current (mA) response time(S)	Minimum sectional area of power line (mm <sup>2</sup> )	Minimum sectional area of earthing line (mm <sup>2</sup> )
AV08IMVURA	3N~, 380-415V, 50/60Hz	20.3	25	25	30mA, below0.1s	6	4
AV10IMVURA		21.8	25	25		6	4
AV12IMVURA		23.3	32	32		10	4
AV14IMVURA		27.7	40	40		10	4
AV16IMVURA		32.4	40	40		10	4
AV18IMVURA		36.1	50	50		16	6
AV20IMVURA		42.4	63	63		16	6
AV22IMVURA		48.1	63	63		25	10

**Note:**

1. Select the power supply cabling of each outdoor unit from the following specifications: Cable 5-core, in conformance with design H07 RN-F or 60245 IEC 66. The operating temperature can not be greater than its specified value.

# Electric wiring and the application

- If the power cord length is greater than 20m, please increase the cable cross-sectional area, so as to avoid overload caused by the accident.
- When the voltage drop at the power supply line exceeds 2%, increase the wire diameter appropriately.
- The air switch and power line is calculated according to the maximum power of the unit, and the combination in accordance with the provisions of the combination of different combinations of modules need to follow the specific parameters of the combination module. The new calculation and calculation method refer to the electrician manual.

## Power line installation instructions

- Air conditioning unit is I class appliance, please be sure to take reliable grounding measures.
- Earth resistance should meet the national standard GB 50169 requirement.
- The yellow and green double color line of air conditioning unit is ground wire, do not move for other use, do not cut it. Cannot be fixed with self-tapping screw. Otherwise, the risk of electric shock will be electric.
- The user's power supply must provide reliable grounding. Please don't connect the ground wire to the following places. (1) water pipe (2) gas pipe; (3) drainage pipe; (4) The other places where professionals think are unreliable.
- The power cord and the communication line should not be interwoven together, the distance should be greater than 20cm apart, or it may cause the crew communication to be abnormal.

Please follow the following guidelines:

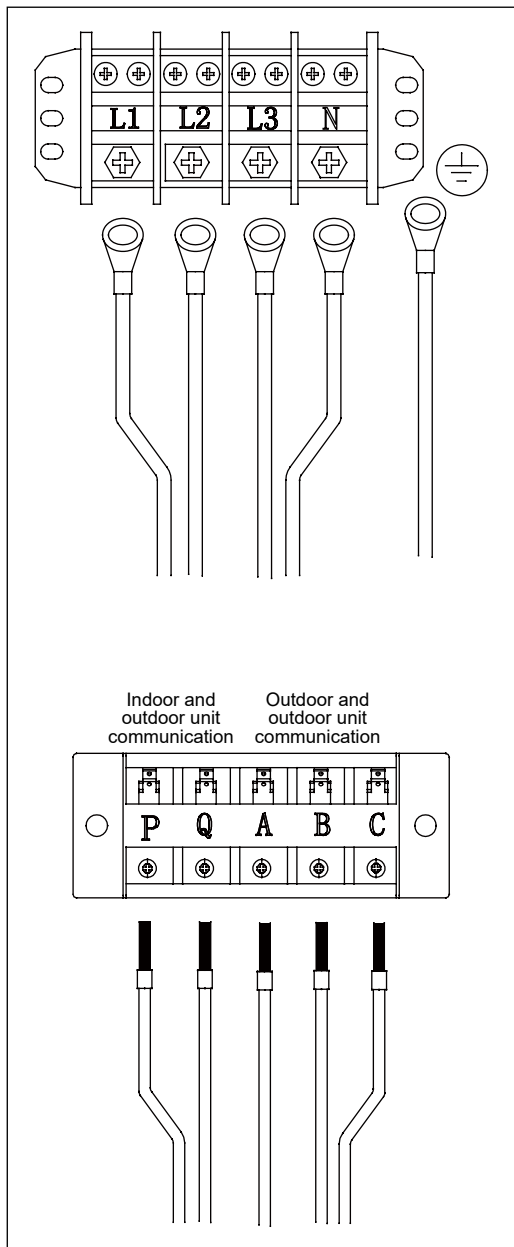

Note:

Please connect the power cord with the appropriate circular terminal. PQ is non-polar, ABC has polarity, must be correct when connecting. The route is as follows:

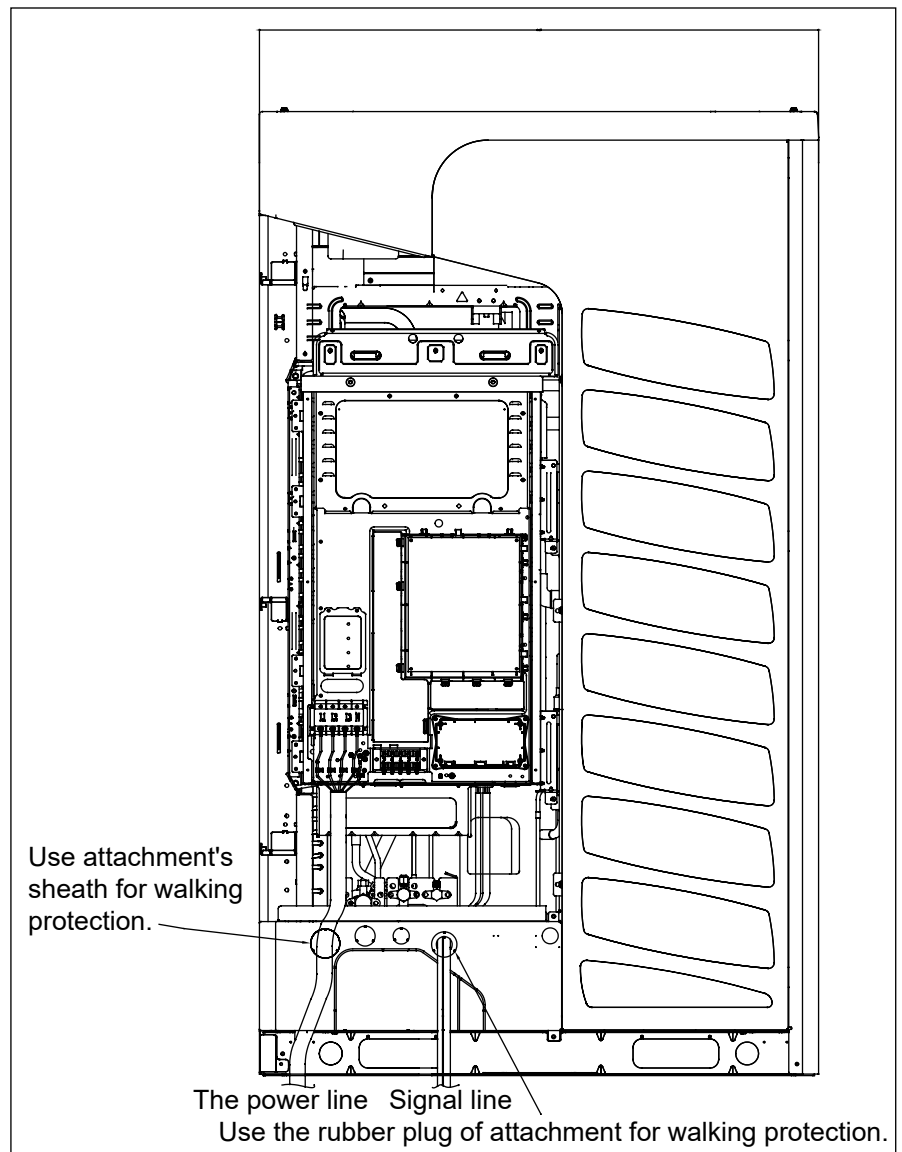

# Electric wiring and the application

## Power line installation instructions

Note:  
When connecting the power cord, please be sure to set aside enough length in the outdoor, which is convenient for turning over the electrical box.

After the maintenance, remove the 5 fixing screws, the electric appliance box body is lifted up slightly, and the box body is rotated to the left, and the steel wire rope in the column is used to check the box to prevent the turning.

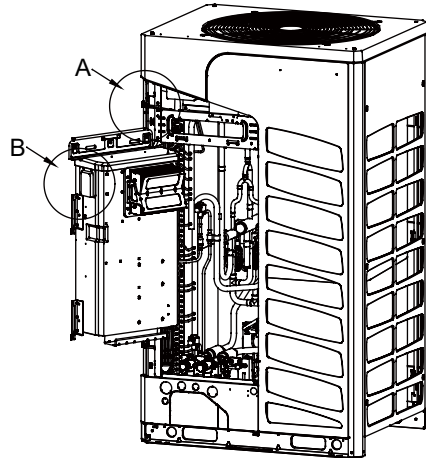
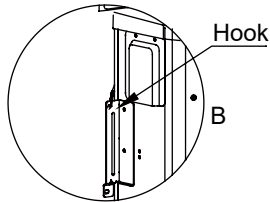
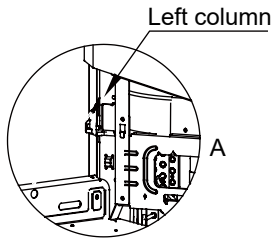

When connecting the power cord, please be sure to set aside enough length in the outdoor, which is convenient for turning over the electrical box.

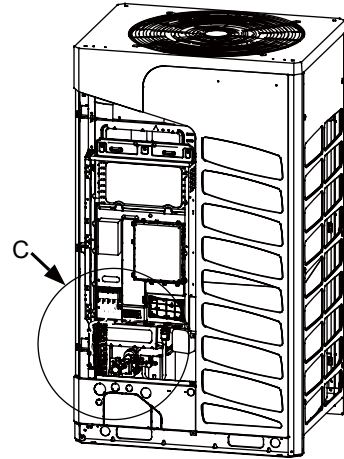
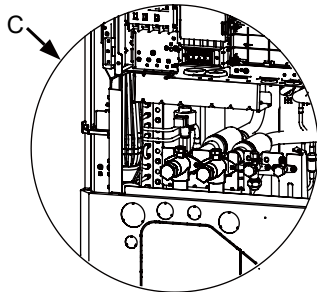

# Electric wiring and the application

Communication wiring figure (Wired)

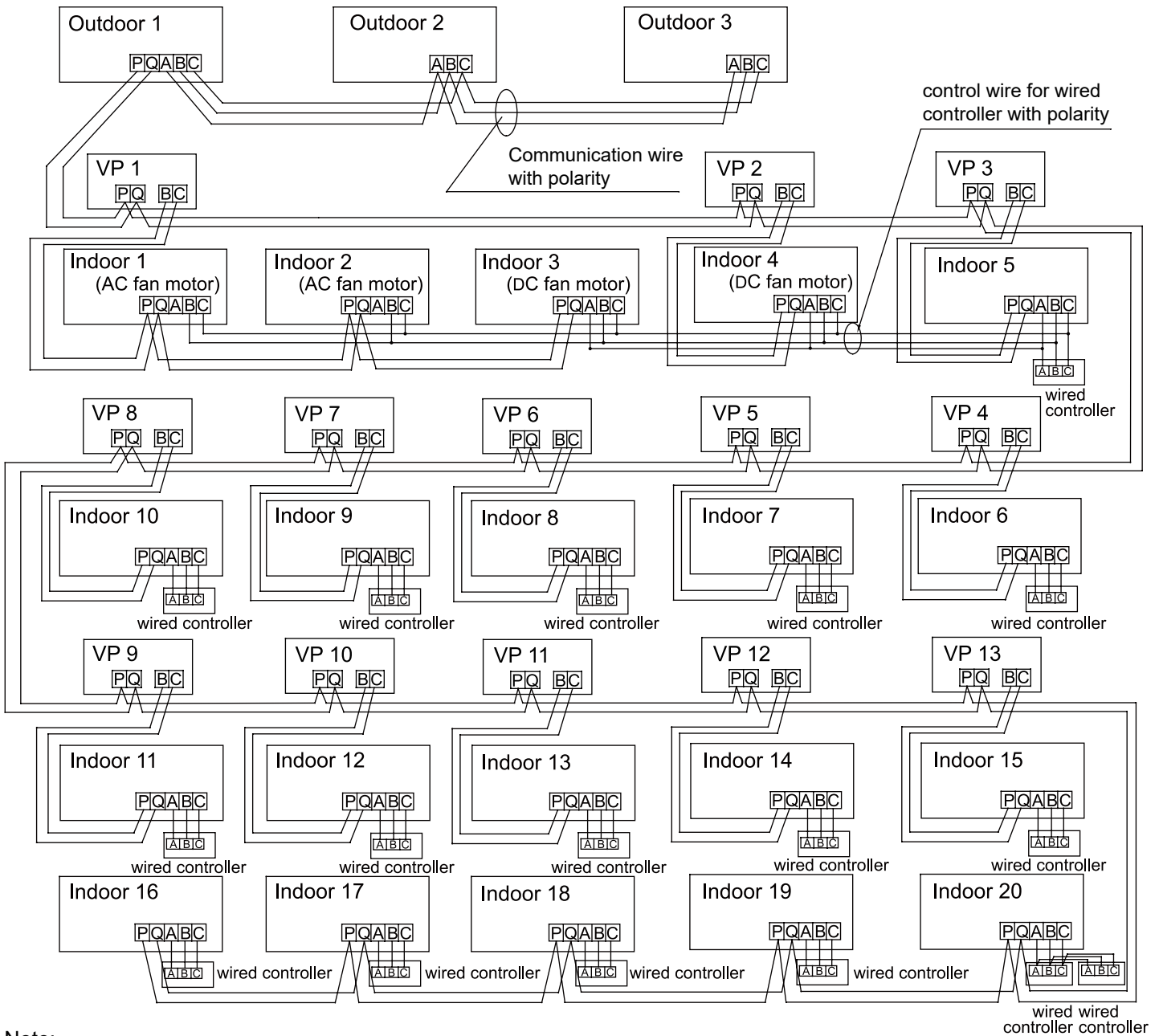

Note:

- Outdoor units are in parallel through 3 polar wires. The outdoor and all VP (cooling and heating switching device) and all indoor units are in parallel through 2 non-polar wires.
- Each VP can be connected to 1~8 indoor units. For the wiring, please refer to the above picture: VP1 is connected to Indoor 1~3, and the capacity of all the indoor units can not be more than the VP's. Indoor units which are not connected to VP just have cooling operation, and the wiring can be referred to Indoor 16~20 on the above picture.
- The communication line must be hand-in-hand serial connection, not using star connection.
- When the length of the single line of communication is not sufficient, the joint connection must be pressed or solder.
- There are three connecting ways between wired control and indoor units:
  - One wired controller controls multiple units, as shown in the above figure, (1-5 indoor units). The indoor unit 5 is the wired control master unit (directly connected to the indoor unit of wired controller) and others are the wired control slave units. 3 and 4 indoor units are DC fan motor models, 1 and 2 indoor units are the AC fan motor models. The wired controller is connected with the master unit and DC fan motor models through three lines with polarity. Other indoor units and the master unit are connected via two lines with polarity. SW01 on the main unit is set to 0 while SW01 on other slave units are set to 1, 2, 3 and so on in turn. (Please refer to the dip switch setting)

# Electric wiring and the application

B. One wired controller controls one indoor unit, as shown in the above figure (indoor unit 6-19). The indoor unit and the wired controller are connected via three lines with polarity.

C. Two wired controllers control one indoor unit, as shown in the figure (indoor unit 20). Either of the wired controllers can be set to be the master wired control while the other is set to be the slave wired controller. The master wired controller, slave wired controller and indoor units are connected via three lines with polarity.

## Communication wiring figure (wireless)

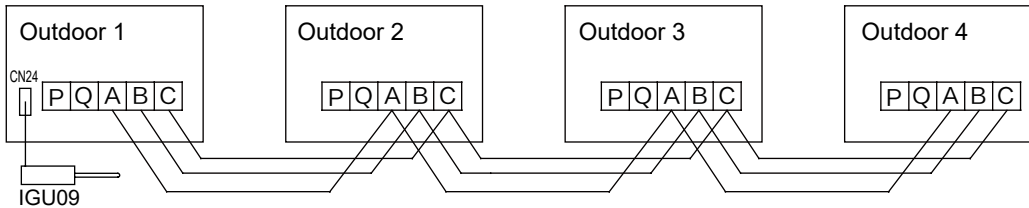

When the outdoor unit is combined, only the host machine is installed IGU09, and the sub machine is connected with the main machine through the communication terminal of the A/B/C.

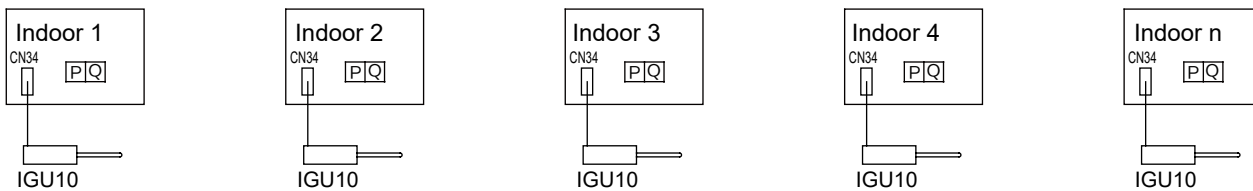

Note:

If the system unit adopts Zigbee wireless communication, it must adopt wireless and wired hybrid mode, that is, wired communication between the host outdoor unit and the first valve box, wireless communication between the valve box and the connected indoor units. Wired communication is used between the valve box and the valve box and between the valve box and the single cold indoor units (the indoor units not connected to the valve box).

## IGU09 installation method

1. Remove the outdoor unit cover, install the IGU09 in the slot inside the top cover, and use the tape (self) fixed. Place the IGU09 antenna down 90 ° at right angles.

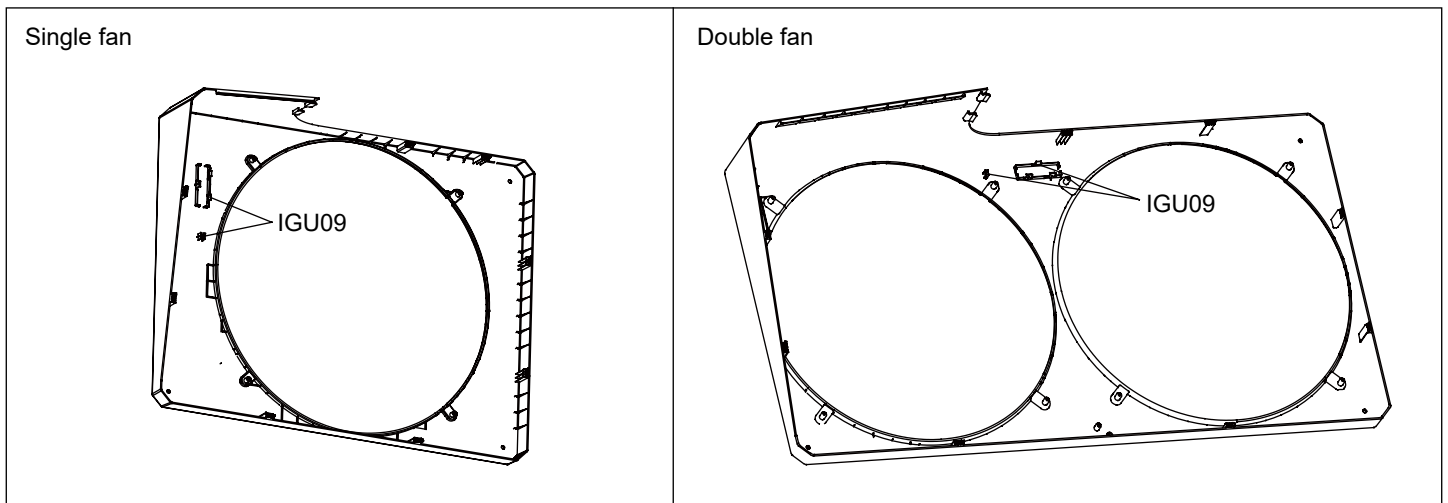

# Electric wiring and the application

2. Follow the instructions to route.

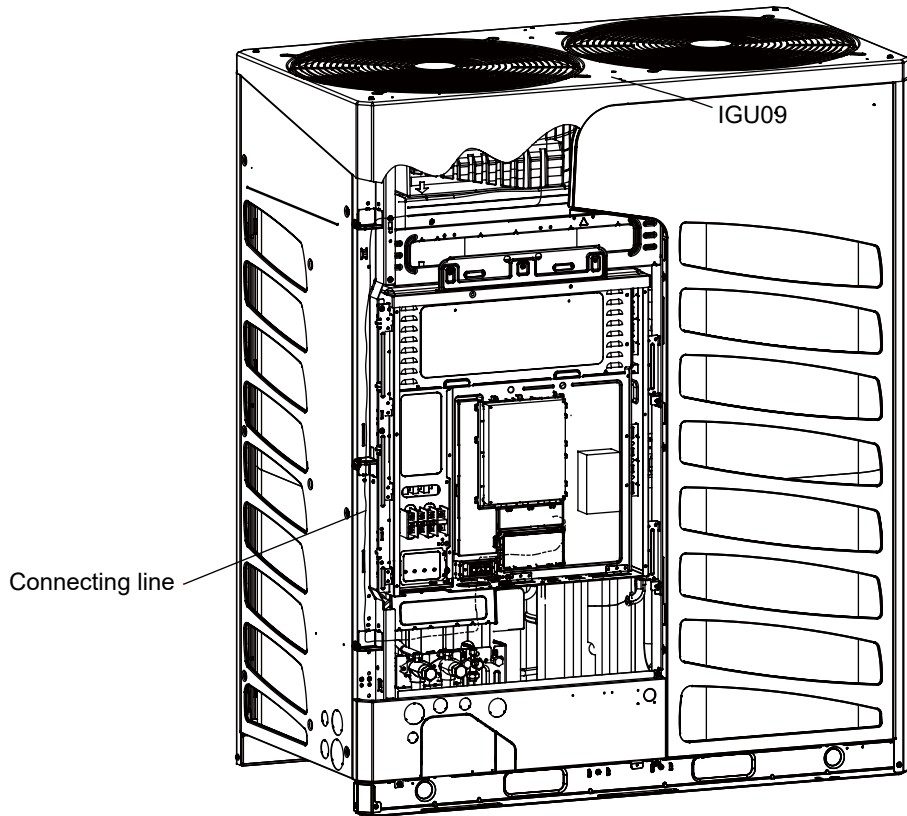

3. Make the dial setting - see the setting method.

4. Installation notes - see the IGU09 installation instructions.

## Internal layout of electric appliance box

For example

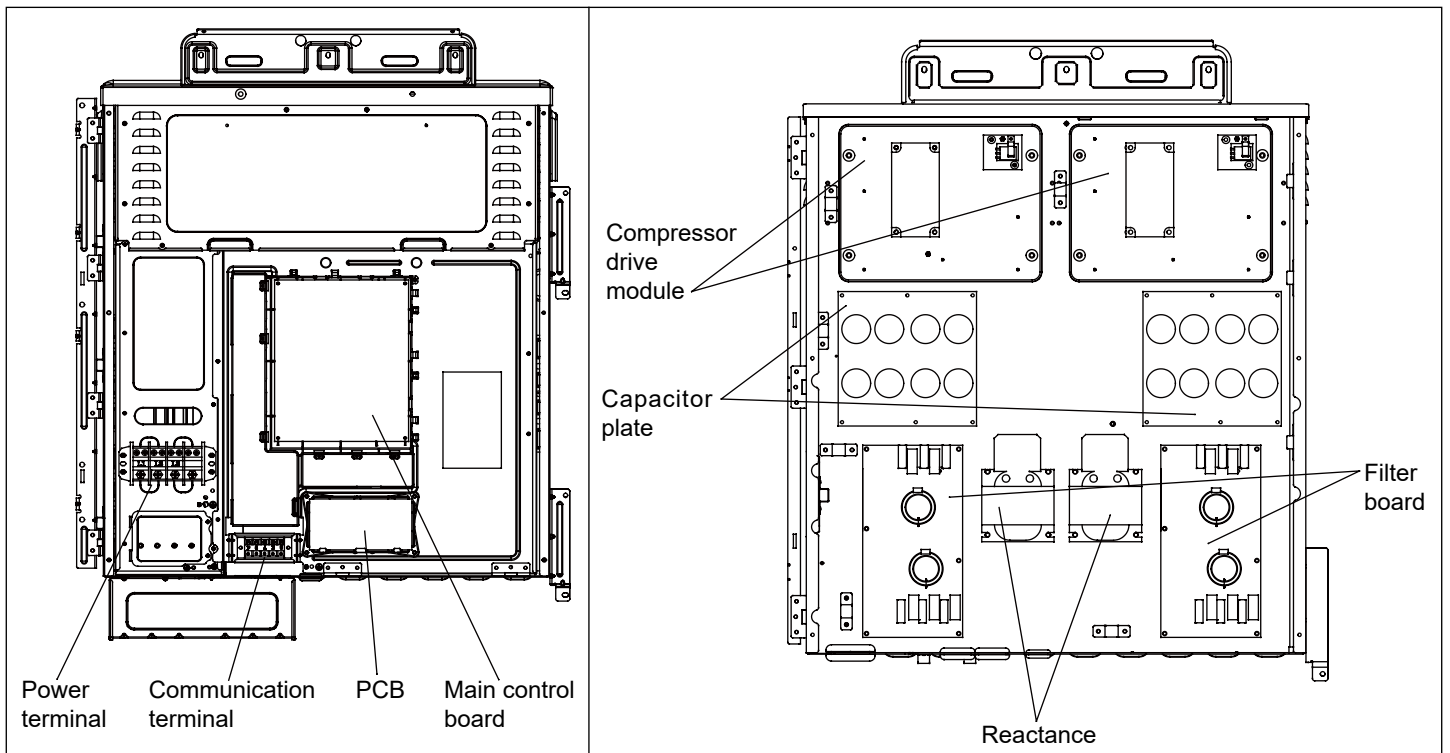

# Electric wiring and the application

## Outdoor dip switch introduction

Identification:

- Physical master unit: by setting dip switch, the unit number is 0. It is used to communicate with indoor unit, also it is the organizer of outdoor communications as communication master unit.
- Functional master unit: the outdoor with the highest priority of running, the priority class is 0.
- Physical slave unit: by setting dip switch, the unit number is not 0.
- Functional slave unit: the outdoor without the highest priority of running, the priority class is 1~3.
- Group class setting: physical master unit setting is valid, which can be used for all the units. For example, silence, snow-proof, piping length etc setting. Set all kinds of state on the physical master unit as a representative.
- Single class setting: only be used for the single unit, instead of the whole group. For example, sensor backup running, inverter board selection etc.
- In the following table, 1 is ON, 0 is OFF.

### ① BM1 introduction

BM1_1	outdoor searching after startup	0	begin to search outdoor		Group class (physical master unit is valid)
		1	stop searching outdoor and lock the quantity		
BM1_2	indoor searching after startup	0	begin to search indoor		
		1	stop searching indoor and lock the quantity		
BM1_3	start up after pre-heating for 6 hours	0	allow(must be electrified for 6 hours)		
		1	forbidden(can start up immediately)		
BM1_4	Outdoor mode setting	0	Normal (default)		
		1	Only Cool		
BM1_5	Outdoor hydrostatic selection	0	Non hydrostatic pressure		
		1	high hydrostatic pressure		
BM1-6	Indoor and Outdoor communication protocol	0	new		
		1	old		
BM1_7 BM1_8	address setting	BM1_7	BM1_8	unit number	
		0	0	0# (physical master unit)	
		0	1	1#	
		1	0	2#	
		1	1	3#	

### ② BM2 introduction

BM2_1 BM2_2	Indoor and outdoor unit new protocol communication type setting (BM1_6 selection of the new agreement is valid for 0)	BM2_1	BM2_2	Indoor and outdoor unit communication category set	Group class (physical master unit is valid)
		0	0	Wired 9600bps General Agreement (ex factory default)	
		0	1	Wired 9600bpsNew2 upgrade protocol	
		1	0	Wireless 9600bps communication	
		1	1	Reserve	
BM2_3	Outdoor unit heat mode setting (BM1_4 =0)	0	Normal(default)		
		1	Only Heat		
BM2_4	Outdoor machine lock IGU10 MAC address	0	Lock IGU10 address (default)		
		1	Allow new IGU10 to join		
BM2_5	Completely empty the wireless external mode EEPROM	0	Normal (default)		
		1	Digital tube 3 dial the first dial to the 1-1-1, the code from OFF to ON after the empty		
BM2_6	Communication conversion board charging module (wireless communication)	0	No (default)		
		1	Yes		
BM2_7 BM2_8	Reserve	0	Reserve		

# Electric wiring and the application

## ③ BM3 introduction

BM3_1 BM3_2 BM3_3	Outdoor machine model set	BM3_1	BM3_2	BM3_3	Outdoor	The outdoor machine is effective
		0	0	0	Normal	
		0	0	1	Update use	
		0	1	0	Enhanced vapor injection model	
		0	1	1	Three pipe model	
BM3_5 BM3_6 BM3_7 BM3_8	Outdoor horse power setting	BM3_5	BM3_6	BM3_7	BM3_8	Outdoor horse
		0	0	0	0	6HP
		0	0	0	1	8HP
		0	0	1	0	10HP
		0	0	1	1	12HP
		0	1	0	0	14HP
		0	1	0	1	16HP
		0	1	1	0	18HP
		0	1	1	1	20HP
1	0	0	0	22HP		

## ④ BM4 introduction: Group class (physical master unit is valid)

BM4_1 BM4_2	ModeBus Centralized control protocol selection	BM4_1	BM4_2	Protocol selection			
		0	0	Third party standard MODBUS protocol (default)			
		0	1	Computer management protocol			
		1	0	Specific centralized control protocol			
		1	1	Reserve			
BM4_4 ~ BM4_8	ModeBus centralized control communication address	BM4_4	BM4_5	BM4_6	BM4_7	BM4_8	ModeBus set control communication address (IGU02 using the address in brackets)
		0	0	0	0	0	address1 (0)
		0	0	0	0	1	address2 (1)
		0	0	0	1	0	address3 (2)
		0	0	0	1	1	address4 (3)
		0	0	1	0	0	address5 (4)
		0	0	1	0	1	address6 (5)
		0	0	1	1	0	address7 (6)
		0	0	1	1	1	address8 (7)
		0	1	0	0	0	address9 (8)
		0	1	0	0	1	address10 (9)
		...	...	...	...	...	.....
1	1	1	1	1	address32 (31)		



# Electric wiring and the application

## Outdoor machine digital tube display settings

The contents of the display are defined as follows:

- Key parts: long press the left START (SW5) control to enter, short press above UP (SW4) data increase, short press down DOWN (SW7) data reduction, long press the right STOP (SW6) control exit
- Dial: SW1, SW2, SW3: set the turntable dial switch is 0 - 15
- (Note: the dial plate, with the letters A for 10, B for 11, C for 12, D for 13, E for 14, F for 15)
- Display parts: LD1, LD2, LD3, LD4:4 digital tube from left to right

### ① Indoor machine parameter view

You can view the indoor machine 128 sets of parameters: SW1 and SW2 represent the indoor machine address, SW3 range 3-14 can view the indoor machine parameters.

SW1	SW2	address
0	0-15	1 to 16 (address 0#-15#)
1		17 to 32 (address 16#-31#)
2		33 to 48 (address 32#-47#)
3		49to 64 (address 48#-63#)
7		65 to 80 (address 64#-79#)
8		81 to 96 (address 80#-95#)
9		97 to 112(address 96#-111#)
10		113 to 128(address 112-127#)

SW3	function	Digital tube LD1 ~ 4 display
3	Indoor unit communication check and program version	Communication normal display indoor machine program version (1 decimal), the communication interrupted normal display "0000" (5 consecutive round of no communication success), communication has not been normal display "---- ----". Such as 3.9, said the machine version number is V3.9
4	Indoor unit failure	Display indoor unit fault code, no fault display 0
5	Indoor unit capacity	The indoor unit capacity (horse, 1 decimal places), 1.5 horse show 1.5
6	Indoor unit expansion valve opening	expansion valve opening ( pulse )
7	Indoor unit environment temperature Tai	environment temperature(℃ )
8	Indoor gas temperature Tc1	gas temperature Tc1 (℃)
9	Indoor liquid temperature Tc2	liquid temperature (℃)
10 (A)	Indoor unit boot mode, the actual operation of wind speed and SCODE code	LD1 said the boot mode O: stop C: refrigeration H: heating LD2 said the actual operating speed of the indoor machine (0- stop, 1- low speed, 2- Middle speed , 3- high speed), LD3 and LD4 are represented by SCODE codes (0 ~ 15). Such as C311 said the cooling operation of high speed, SCODE 11.
11 (B)	Indoor set temperature Tset	Indoor set temperature (℃)
12 (C)	Indoor unit consistency control setting	Display the indoor unit corresponding to the same contract use (0 unallocated group number, their control) Method of setting group and the <E2 control parameters and Display Settings > (Note: all in the unit at the same time can be set by a dial 15-0-2 set "in the same unit drive outside unit control", 0- indoor unit according to the number of automatic control, 1- indoor unit with all contract, all within each 2- indoor unit control, banned from drive off)
13 (D)	Low temperature automatic running function of indoor unit	Shows whether the machine has this function, 0 - No 1 - there are Setting the method with the <E2 control parameters display and Settings > Note: all within the machine at the same time setting can be set by dialing 15-1-2 "within the machine at low temperature automatic operation at the same time control selection", 0- automatic control, 1- all within the machine is valid, 2- all within the machine is invalid

# Electric wiring and the application

SW3	function	Digital tube LD1 ~ 4 display
14 (E)	Forced indoor mechanism cooling / heating / shutdown	(1) press START (SW5) for 2 seconds, to enter the instruction set state, flashing display instructions. (2) according to UP (SW4) or DOWN (SW7) ( ) adjustment instructions (COOL/ HEAT/OFF). (3) after the adjustment is completed, according to STOP (SW6) for 2 seconds, the implementation of the instruction set and stop flashing display

## ② Outdoor unit parameter view

0~3 SW1 is used to select the outdoor machine number, to select the different machine. SW3 range of 0, 1, 15, expressed as the observation of outdoor machine parameters.

(the host can display the parameters of the other outdoor machine and the indoor machine parameters, and the sub machine only displays the machine parameter SW1 is 0).

(1) The first boot, the first sub search engine, from left to right circular display 1:0, if found a table display 2:01 two table display 3:012. "3:012" means a total of 3 units of the system, 012 said the address of the machine. (": " the actual display "=").

(2) Lock machine units, start the search within the machine number, cycle "- in - machine units", such as "-6-" said the system connects the 6 station machine

(3) After the search is completed, the display of the machine's fault code, the machine has no fault when the display 0.

SW1	SW2	SW3	function	Digital tube LD1 ~ 4 display
Outdoor unit address 0-3	0	0	Display outdoor unit fault code	External machine bus data transfer fault code. If there is no fault display on the electric heating 6 hour countdown time to form a stopwatch Press START (SW5) for 2 seconds, 1111, into the fault query state, can query the last 10 faults occur: fault and fault code flashing display serial number, each by 1 UP (SW4) plus 1 serial number, each by 1 DOWN (SW7) serial number minus 1; 2min automatic exit. Steady state Press STOP (SW6) for 2 seconds, display 0000, quit the status of the query, stop flashing display; The dial in 13,0,0, press START (SW5) 2 seconds, 1111, can clear the historical record of failure
	1	0	Display outdoor unit priority and outdoor unit capacity	LD1: Display priority of outdoor unit LD2: Display "-" LD3-4: Display outdoor unit capacity (Horse)
	2	0	Display operation mode and outdoor unit operation output ratio	LD1 said O: stop C: refrigeration H: heating LD2-LD4 said: 60 of the ability to express the output of 60%
	3	0	Outdoor fan speed 1	345 representation 345rpm Press START (SW5) for 2 seconds, 1111, enter the set state: flashing, each by 1 UP (SW4) level of wind speed increased by 1 per level, by 1 DOWN (SW7) wind speed increased by 1 grade; 5min automatically exit the setting state
	4	0	Outdoor fan speed 2	Press STOP (SW6) for 2 seconds, display 0000, quit the set state, stop flashing display
	5	0	Frequency converter INV1 current frequency	110 representation 110.0Hz Press START (SW5) for 2 seconds, display 1111, enter the set state: flashing display, each according to the 1 UP (SW4) frequency rise 1Hz, every 1 times DOWN (SW7) frequency drop 1Hz; 5min after automatically quit the set state.
	6	0	Frequency converter INV2 current frequency	Press STOP (SW6) for 2 seconds, display 0000, quit the set state, stop flashing display; (When the system is in trouble, the compressor is forbidden to start.)

# Electric wiring and the application

SW1	SW2	SW3	function	Digital tube LD1 ~ 4 display
Outdoor unit address 0-3	7	0	Outdoor unit LEVa1 open degree	0---470pluse Press START (SW5) for 2 seconds, 1111, enter the set state: flashing, press UP (SW4) valve fully open, according to DOWN (SW7) 2min after the valve is fully closed; automatically exit the setting state Press STOP (SW6) for 2 seconds, display 0000, quit the set state, stop flashing display
	8	0	Outdoor unit LEVa2 open degree	
	9	0	Outdoor unit LEVb open degree	
	10 (A)	0	Outdoor unit LEVc open degree	LD1: 4WV : 1 open 0 close——High to the left LD2: SV1 : 1 open 0 close LD3: SV3: 1 open 0 close LD4: Reserved, Display “-”
	11 (B)	0	Outdoor unit output electromagnetic valve	
	12 (C)	0	Outdoor unit output electromagnetic valve	LD1: SV6: 1 open 0 close——High to the left LD2: SV9: 1 open 0 close LD3: SV10: 1 open 0 close LD4: SV11: 1 open 0 close
	13 (D)	0	Outdoor unit output electromagnetic valve	LD1: SVX: 1 open 0 close LD2: SVY: 1 open 0 close LD3: Reserved, Display “-” LD4: Reserved, Display “-”
	14 (E)	0	Heating belt output	LD1: CH1: 1 open 0 close LD2: CH2: 1 open 0 close LD3: CHa : 1 open 0 close LD4: Reserved, Display “-”
15 (F)	0	Program version	1 representation Ver1.0	

SW1	SW2	SW3	function	Digital tube LD1 ~ 4 display
Outdoor unit address 0-3	0	1	Pd	Unit: kg, 2 decimal places
	2	1	Ps	
	3	1	Td1	
	4	1	Td2	Unit: degree
	5	1	Tdef	
	7	1	Toil1	
	8	1	Toil2	
	9	1	Toci1	
	14 (E)	1	Tsacc	
	15 (F)	1	Th	

SW1	SW2	SW3	function	Digital tube LD1 ~ 4 display
Outdoor unit address 0-3	0	15 (F)	Reserved	25 Unit: degree
	1	15 (F)	Tao	
	2	15 (F)	Pd_temp	
	4	15 (F)	Ps_temp	
	5	15 (F)	Tliqsc	
	6	15 (F)	Tsco	
	8	15 (F)	Frequency conversion press INV1 running time	Unit: Min
	9	15 (F)	Frequency conversion press INV2 running time	Unit: Min
	10 (A)	15 (F)	Frequency conversion press INV1 current CT	Unit: A, 1 decimal places
	11 (B)	15 (F)	Frequency conversion press INV2 current CT	Unit: A, 1 decimal places
	12 (C)	15 (F)	Frequency conversion compressor INV1 DC voltage	Unit: V
	13 (D)	15 (F)	Frequency conversion compressor INV2 DC voltage	Unit: V

# Electric wiring and the application

SW1	SW2	SW3	function	Digital tube LD1 ~ 4 display
Outdoor unit address 0-3	14 (E)	15 (F)	Frequency converter INV1 module temperature	Unit: degree
	15 (F)	15 (F)	Frequency converter INV2 module temperature	Unit: degree

### ③ System status display and control (host)

SW1	SW2	SW3	function	Digital tube LD1 ~ 4 display
0	0	2	Refrigerant type	410A represents 410A refrigerant
0	1	2	The same outdoor unit total number and total capacity	LD1: The total number of outdoor unit LD2: Display “-” LD3/ LD4: Total outdoor unit capacity (unit: Horse) For example: 3-48 said 3 outdoor machines, with a total capacity of 48 horses
0	2	2	Total indoor unit capacity	50 represents 50 horses
0	3	2	Number of valve boxes and indoor units in the same system	LD1/ LD2: Number of valve boxes (three-line model) LD3/ LD4: number of indoor units For example: 0206 means 2 valve boxes, 6 indoor units
0	4	2	Number of indoor unit working	Temperature sensor ON as a sign of the work of the indoor unit
0	5	2	With the outdoor unit running mode the same indoor unit number	For example: 13
0	6	2	Cooling target temperature	Unit: degree
0	7	2	Heating target temperature	
0	8	2	Automatic recovery of refrigerant Note: the end of the recovery must be canceled or reset	When the outdoor stops, press START (SW5) for 2 seconds, display 1111, start. (the outdoor is set to work in a state of operation) Press STOP (SW6) for 2 seconds, display 0000, stop
0	10 (A)	2	Test run setup Note: the end of the test run must be canceled or reset	When the outdoor stops, press START (SW5) for 2 seconds, display 1111, start. (the outdoor is set to work in a state of operation) Press STOP (SW6) for 2 seconds, display 0000, stop
0	11 (B)	2	Outdoor unit mode	0-normal C-only cool H-only heat
0	12 (C)	2	Indoor unit expansion valve fully open	Press START (SW5) for 2 seconds, display 1111, indoor valve fully open 2 minutes, 2 minutes after the automatic shutdown valve
0	13 (D)	2	All the indoor unit for cooling	Press START (SW5) for 2 seconds, display 1111, fully open; Press STOP (SW6) for 2 seconds, 0000, closed
0	14 (E)	2	All the indoor unit for heating	
0	15 (F)	2	Cancel all manual control (running class)	Press START (SW5) for 2 seconds, display 1111 cancel; or press STOP (SW6) for 2 seconds, display 0000, cancel Remove all manual control (part), closed indoor unit

### ④ E2 control parameters display and setting

Each need to be set, setting method:

(1) Press START (SW5) for 2 seconds, display 1111, enter the set state, flashing display the current value

(2) According to UP (SW4) or DOWN (SW7) adjustment parameters

(3) After the adjustment is completed

<A> In the current state of the code, effectively set the time by pressing STOP (SW6) for 2 seconds, showing 0000, keeping the current settings and exit the set state, stop flashing display, waiting for 2 minutes after the power off and then re power up

<B> The current set time is not set by STOP (SW6) or change the dial selection, do not save the current set value, exit the set state, stop flashing display

<C> Effective time setting: the machine with the contract number and set off a low temperature automatic operation function for 10 minutes, the other for 30 seconds.

# Electric wiring and the application

SW1	SW2	SW3	function	Digital tube LD1 ~ 4 display	Control range
15 (F)	0	2	In the same machine drive off control selection	0- machine automatic control according to the group number, all within the machine with 1- drive, 2- all in each machine control, drive off with ban	Group class (physical master unit is valid)
15 (F)	1	2	Selection of low temperature automatic operation control for indoor unit	0- within the machine automatic control, 1- all within the machine is valid, 2- all the inside of the machine is invalid	
15 (F)	2	2	Pipe length selection	0: short pipe length; 1: middle pipe length; 2: long pipe length	
15 (F)	3	2	Defrosting conditions selection	0- normal area, 1- area easy to frost	
15 (F)	4	2	Operation mode priority	0- first open priority; 1- after opening priority 2- cooling priority; 3- heating priority	
15 (F)	6	2	Heating limit when Outdoor temp Over 25 degree	0-shows no limitation, 1-shows limitation	
15 (F)	7	2	Silent running option	0-without silent operation, 1- silent operation 1, 2- silent operation 2, 3- silent operation 3, 4- silent operation 4	
15 (F)	8	2	snow-proof operation setting	0-without snow-proof operation, 1- without snow-proof operation	
15 (F)	9	2	When the main outdoor machine is running, the choice of the operation of the wind turbine is stopped.	0-stop, 1-run	
15 (F)	12 (C)	2	Power limit operation control mode selection	0- By E2 value, 1- By external contact DRM	
15 (F)	13 (D)	2	Power output ratio selection (E2 control method is valid)	Maximum capacity to allow the maximum number of files, a total of 11 stalls, 0 stalls for 10, 0%, 100%	

# Failure code

Failure code description: (failure code of the whole system is showed as 8 bits, so totally 256 codes. Indoor failure code should be judged by the table and the unit number)

- Outdoor failure code exists in EEPROM, in which 5 failure codes can be kept.
- Indoor failure code exists in EEPROM, in which 5 failure codes can be kept.
- Can clear failure code by indoor or outdoor.

Failure codes are distributed as following:

- 0~19: indoor failure code
- 20~99: outdoor failure code
- 100~109: DC motor failure code
- 110~125: inverter module failure code
- 126~127: soft auto-check failure code

Physical master unit:

Dip switch SW9, SW10, SW11 are at 0, 0, 0, digital tube displays failure code 20~127, it is the master failure code.

Dip switch SW9, SW10, SW11 are 1, 0, 0, digital tube displays failure code 20~127, it is failure code of No. 1 slave unit.

Dip switch SW9, SW10, SW11 are 2, 0, 0, digital tube displays failure code 20~127, it is failure code of No. 2 slave unit.

Physical slave unit:

Dip switch SW9, SW10, SW11 are at 0, 0, 0, digital tube displays failure code 20~127, it is single slave unit failure code.

Outdoor failure code display principle on wired controller:

When outdoor compressor is running, indoor wired controller will display the failure code of outdoor with higher priority.

When compressor stops, it displays all indoor failures. The indoor failures will be classified as below: sensor failure, inverter board failure, fan motor driving board failure, any protections etc.

## Outdoor unit failure code

Digital tube indication on master unit	Failure code definition	Failure description	Remarks
20-0	Defrosting temp.sensor Td failure	AD value is below 11(open circuit) or over 1012(short circuit)for 60 seconds,in cooling mode,if the sensor is abnormal,the unit does not deal with it,besides,in defrosting and within 3 minutes after defrosting,no alarm	resumable
21	Ambient temp.sensor Ta failure	AD value is below 11(open circuit) or over 1012(short circuit)for 60 seconds	resumable
22-2	Suction temp.sensor Ts(acc) failure		
23-0	Discharging temp. sensor Td1 failure	AD value is below 11(open circuit) or over 1012(short circuit)for 60 seconds	resumable
23-1	Discharging temp. sensor Td2 failure		
24-0	Modular heat sensor Th failure	AD value is below 11(open circuit) or over 1012(short circuit)for 60 seconds	resumable
24-1	Oil temp.sensor Toi1 failure		
24-2	Oil temp.sensor Toi2 failure		
25-0	Inlet temp.of heat exchanger Toci1 failure	AD value is below 11(open circuit) or over 1012(short circuit)for 60 seconds	resumable
26-0	Indoor communication failure	For continuous 200 cycles,can not find connected indoors	resumable
26-1		For continuous 270 seconds,the searched indoor quantity is less than the set quantity	
26-2		For continuous 170 seconds,the searched indoor quantity is more than the set quantity	

# Failure code

Digital tube indication on master unit	Failure code definition	Failure description	Remarks
26-3	Outdoor unit and VP-box communication failure	The searched vp box quantity is less than set quantity for continuous 5 minutes	
26-4		The searched vp box quantity is more than set quantity for continuous 5 minutes	
27-0	Oil temp.too high protection (Toil1)	Toil $\geq$ 120°C continuous 2sec exceeds the set value after shutdown alarm; the alarm condition after stopping the oil temperature below 10 degrees, automatic recovery after 2min50s. Four times an hour to confirm the fault	Once confirmation un-resumable
27-1	Oil temp.too high protection (Toil2)		
28	High pressure sensor Pd failure	AD value is below 11(open circuit)or over 1012(short circuit)for 30 seconds	resumable
29	Low pressure sensor Ps failure	AD value is below 11(open circuit)or over 1012(short circuit)for 30 seconds	
30-0	High pressure switch HPSi failure	If disconnect for 2s continuously,alarm.If alarm 3 times in an hour,confirm the failure	Once confirmation un-resumable
30-1	High pressure switch HPS2failure		
32-0	Heat exchanger outlet temp. Tsc0 failure	If AD value is below 11 (open circuit) or over 1012 (short circuit) for 60 seconds, alarm, sensor has no alarm when abnormal in heating mode.	resumable
32-1	Liquid pipe SC temp. of subcooler Tliqsc failure		
33-0	EEPROM failure	AT24C04 EEPROM communication failure	Once confirmation un-resumable
33-2		AT24C04 EEPROM data check failure(model code,check sun etc)	
33-3		AT24C04 EEPROM data check failure(data beyond limit,reverse sequence etc)	
34-0	Discharging temp.too high protection (Td1)	Td $\geq$ 120°C continuous 2sec exceeds the set value after shutdown alarm; the alarm condition after stopping the oil temperature below 10 degrees, automatic recovery after 2min50s. Four times an hour to confirm the fault	Once confirmation un-resumable
34-1	Discharging temp.too high protection (Td2)		
35-0	4-way valve reversing failure	After 4-way valve is electrified for 10 minutes,if the below conditions can be met for continous 10 seconds,that is conversing successfully. This outdoor compressor is running normally Td1orTd2-Tdef1 $\geq$ 10°C & Toci-Tao $\leq$ 5°C & Pd-Ps $\geq$ 0.3MPa Otherwise, the system alarms reversing failure If it occurs 3 times in an hour,confirm the failure	Once confirmation un-resumable
35-1	4-way valve reversing failure	After the start of the main outdoor machine 20min still have a child of the four way valve is not on the electricity is reported 35-1 fault. 2 times an hour to confirm the fault.	Once confirmation un-resumable
36-0	Oil temp.too low protection (Toil1)	In normal operation,if Toil < CT+10°C for continuous 5 minntes,the unit stop and alarm.2 minutes and 50 seconds later,resume automatically.If it occurs 3 times in an hour,confirm the failure	Once confirmation un-resumable
36-1	Oil temp.too low protection (Toil2)		
39-0	Low pressure sensor Ps too low protection	After compressor is running(except for residual operation),if in cooling,Ps < 0.01MPa or in heating, Ps < 0.05MPa for continuous 5 minutes, alarm and stop。 2 minutes and 50 seconds later, resume automatically。 If it occurs 3 times in an hour, confirm the failure。	Once confirmation un-resumable

# Failure code

Digital tube indication on master unit	Failure code definition	Failure description	Remarks
39-1	Compression ratio too high Protection	After compressor is running, compression ratio $\epsilon > 10.0$ for continuous 5 minutes, stop and alarm. 2 minutes and 50 seconds later, resume automatically. If it occurs 4 times in an hour, confirm the failure.	Once confirmation un-resumable
40	High pressure sensor Pd too high protection	If $P_d \geq 4.15 \text{MPa}$ , alarm and stop, 2 minutes and 50 seconds later, resume automatically. If it occurs 3 times in an hour, confirm the failure.	Once confirmation un-resumable
43-0	Discharging temp. sensor Tdi too low protection	In normal operation, if $T_d < CT + 10^\circ\text{C}$ for continuous 5 minutes, the unit stops and alarms. 2 minutes and 50 seconds later, resume automatically. If it occurs 3 times in an hour, confirm the failure.	Once confirmation un-resumable
43-1	Discharging temp. sensor Td1 too low protection		
45	Communication failure between outdoors	Continuous 30 seconds no communication	resumable
46-0	Communication failure with INV1 module board	Continuous 30 seconds no communication	
46-1	Communication failure with INV2 module board	Continuous 30 seconds no communication	
46-4	Communication with fan 1 module board	Continuous 30 seconds no communication	
46-5	Communication with fan 2 module board	Continuous 30 seconds no communication	
47	Communication failure with wireless module	Wireless module can not detect 2 minutes alarm	
51-0	LEVa1 over current protection	LEV drive chip detection	resumable
51-1	LEVa2 over current protection	LEV drive chip detection	resumable
52-0	LEVa1 disconnection fault	LEV drive chip detection	resumable
52-1	LEVa2 disconnection fault	LEV drive chip detection	resumable
74	Emergency stop	External interface control (The machine will stop quickly after switch cut off)	resumable
75-0	High and low pressure difference is too small	$P_d - P_s = 0.35 \text{Mpa}$ for 3 minutes, if the outdoor protective stop. Protect stop after 5 minutes, then restart.	Once confirmation un-resumable
76-0	Incorrect outdoor address or capacity setting	The number of sub machine and host data does not match the EEPROM set	Reset
76-1		The address of sub machine and host data does not match the EEPROM set	
76-2		The capacity setting of sub machine and host data does not match the EEPROM set	
83	Incorrect parameter setting or incorrect match of outdoor unit	Outdoor machine type dial code settings error or with the host model does not match	Non recoverable
99-X	Program self fault	X=0~5	resumable



# Failure code

Digital tube indication on master unit	Failure code definition	Failure description	Remarks
108	Module rectifier side software transient overcurrent	-	-1: compressor module 1; -2: compressor module 2; -4: fan module 1; -5: fan module 2; Four fault confirmation for one hour, Once confirmation un-resumable
109	Module rectifier side current detection circuit anomaly	-	
110	Module hardware overcurrent	-	
111	Compressor out of step	In the process of starting or running, the rotor position can not be detected for 6 times in a row, and the INV control board is automatically restored after stopping 5S	
112	High temperature of module radiator	The temperature more than 94℃ fault alarm. Automatic recovery of INV control board when temperature is 94℃	
113	Module overload	-	
114	Inverter input power abnormal	P/N voltage<420V, alarm P/N voltage≥420V, auto recovery	
		P/N voltage>642V, alarm P/N voltage≤642V, auto recovery	
		Inverter input power voltage sags and brief interruptions	
117	Modular software overcurrent	-	
118	Module boot failure	Compressor 5 consecutive start failure	
119	Module current detection circuit error	Abnormality of current detection sensor, no connection or connection error	
120	Module power supply error	Inverter controller power supply instantaneous interrupt	
121	Module control board power supply abnormal	Inverter controller board power supply instantaneous interrupt	
122	Module radiator temperature sensor abnormal	Temperature sensor resistance is abnormal or not connected	
123	Module rectifier side hardware transient overcurrent	-	
124	Three phase power supply failure	-	
125-0/1	Compressor frequency mismatch	(the current frequency is greater than or equal to INV or +3Hz target frequency (frequency) target actual frequency >0 & =0) for 5 minutes	resumable
125-4/5	Fan speed mismatch (locked rotor)	20rpm run below the 30s, or the target value of 70% to run for up to 2 minutes after the shutdown, automatic recovery after 2 minutes of 50 seconds, one hour and four fault confirmation.	Once confirmation un-resumable
127	MCU reset fault	If the host detects sub machine MCU reset, and the machine is in operation, the host MCU reset the fault, the whole system down; if in the heating mode, then restart the 4WV power, the system re 4WV reversing operation. Four fault confirmation for one hour	Once confirmation un-resumable

# Failure code

In the case of no fault, if the system does not meet the start-up conditions, the host digital display standby code:

555.0	Indoor machine capacity beyond the outdoor machine capacity of 150% or less than 50%, standby system	Indoor machine capacity beyond the outdoor machine capacity of 150% or less than 50%, standby system	resumable
555.1	26 degree standby	Ambient temperature above 26 degrees indoor heat can not boot	
555.2	Low pressure (gas) standby	Refrigeration Ps<0.23Mpa or heating Ps<0.12Mpa start, system standby	
555.3	54 degrees above the cooling outdoor machine is not running	54 degrees above the cooling outdoor machine is not running	
555.5	Power restriction	Power inhibit setting maximum capacity output is 0%	
555.6	Password lock	Password lock system to set the maximum operating time to the system standby	
555.8	No trial running	No trial running	

## Indoor failure code list

Indication on master unit	Indication on wired controller	Flash times of LED5 on indoor PCB/timer LED on remote receiver	Failure code definition
01	01	1	Indoor ambient temp. sensor Ta failure
02	02	2	Indoor coil temp. sensor Tc1 failure
03	03	3	Indoor coil temp. sensor Tc2 failure
04	04	4	Indoor TW sensor failure
05	05	5	Indoor EEPROM failure
06	06	6	Communication between indoor and outdoor failure
07	07	7	Communication between indoor and wired controller failure
08	08	8	Indoor drainage failure
09	09	9	Indoor repeated address
0A	0A	10	Indoor repeated central control address
0C	0C	12	50Hz zero crossing fault
Outdoor failure code	Outdoor failure code	20	Outdoor corresponding failure

# Trial operation and the performance

---

## 5-minute delay function

- If starting up the unit after being powered off, the compressor will run about 5 minutes later against being damaged.

## Cooling/heating operation

- Indoor units can be controlled individually, but cannot run in cool and heat mode at the same time. If the cool mode and the heat mode are existing simultaneously, the unit set latter will be standby, and the unit set earlier will run normally. If the A/C manager sets the unit at cooling or heating mode fixedly, the unit can not run at the other modes.

## Heating mode characteristic

- In operation if outdoor temp. arises, indoor fan motor will turn to low speed or stop.

## Defrosting in heating mode

- In heating mode, outdoor defrosting will affect the heating efficiency. The unit will defrost for about 2~10 minutes automatically, at this time, the condensate will flow from outdoor, also in defrosting, the vapour will appear at outdoor, which is normal. Indoor motor will run at low speed or stop, and outdoor motor will stop.

## The unit operation condition

- To use the unit properly, please operate the unit under the allowed condition range. If operating beyond the range, the protection device will act.
- The relative humidity should be lower than 80%. If the unit runs at the humidity over 80% for a long period, the dew on the unit will drop down and the vapour will be blown from air outlet.

## Protection device (such as high pressure switch)

- High pressure switch is the device which can stop the unit automatically when the unit runs abnormally. When the high pressure switch acts, the cooling/heating mode will stop but the running LED on wired controller will be light still. The wired controller will display failure code.  
When the following cases occur, the protection device will act:  
In cooling mode, air outlet and air inlet of outdoor are clogged.  
In heating mode, indoor filter is sticked with duct; indoor air outlet is clogged.  
When protection device acts, please cut off the power source and re-start up after eliminating the trouble.

## When power failure

- When power is failure in running, all the operations will stop.
- After being electrified again, if with re-satrt up function, the unit can resume to the state before power off automatically; if without re-satrt up function, the unit needs to be switched on again.
- When abnormal occurs in running because of the thunder, the lightning, the interference of car or radio, etc, please cut off the power source, after eliminating the failure, press "ON/OFF" button to start up the unit.

## Heating capacity

- The heating mode adopts the heat pump type that absorbs outdoor heat energy and releases into indoor. So if outdoor temperature goes down, the heating capacity will decrease.

## System marks

- On the condition that multi Outdoor systems are installed, in order to confirm the relationship between outdoor and indoor, please make marks on outdoor electric control box cover to indicate the connected indoor unit. As the below figure:

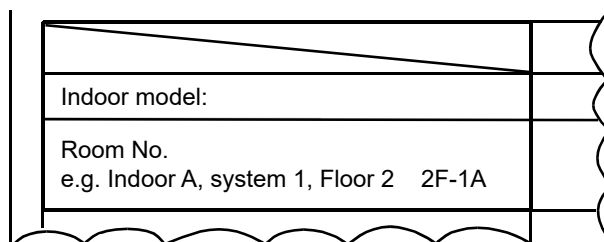

# Trial operation and the performance

---

## **Trial operation**

- Before trial operation:  
Before being electrified, measure the resistor between power terminal block (live wire and neutral wire) and the earthed point with a multimeter, and check if it is over 1MΩ. If not, the unit can not operate.  
To protect compressor, electrify the outdoor unit for at least 12 hours before the unit runs. If the crankcase heater is not electrified for 6 hours, the compressor will not work.  
Confirm the compressor bottom getting hot.  
Except for the condition that there is only one master unit connected (no slave unit), under the other conditions, open fully the outdoor operating valves (gas side, liquid side). If operating the unit without opening the valves, compressor failure will occur.  
Confirm all indoor units being electrified. If not, water leakage will occur.  
Measure the system pressure with pressure gauge, at the same time, operate the unit.
- Trial operation  
In trial operation, refer to the information of performance section. When the unit can not start up at the room temperature, make trial operation for outdoor.

# Move and scrap the air conditioning

---

- When moving, to disassemble and re-install the air conditioning, please contact your dealer for technical support.
- In the composition material of air conditioning, the content of lead, mercury, hexavalent chromium, polybrominated biphenyls and polybrominated diphenyl ethers are not more than 0.1% (mass fraction) and cadmium is not more than 0.01% (mass fraction).
- Please recycle the refrigerant before scrapping, moving, setting and repairing the air conditioning; for the air conditioning scrapping, should be dealt with by the qualified enterprises.







Qingdao Haier Air Conditioner Electric Co.,Ltd.

Haier Industrial Park,Qianwangang Road,Eco-Tech Development Zone,Qingdao 266555,  
Shandong,P.R.C.